

USB 2.0 Ranger[®] 2301 Series

1-Port USB 2.0 CAT 5e/6/7 and Gigabit Ethernet LAN
Extender Systems

User Guide



Thank you for purchasing the USB 2.0 Ranger 2301 or 2301GE-LAN.

Please read this guide thoroughly.

This document applies to the following Part Numbers:

Model	NA System	EU System	UK System	AU System	JP System
Ranger 2301	00-00391	00-00392	00-00393	00-00394	00-00395
Ranger 2301GE-LAN	00-00396	00-00397	00-00398	00-00399	00-00400

FCC Radio Frequency Interference Statement Warning

This device complies with Part 15 of the FCC rules. Operation is subject to the following two conditions: (1) this device may not cause harmful interference, and (2) this device must accept any interference received including interference that may cause undesired operation.

CE Statement

We declare under our sole responsibility that the USB 2.0 Ranger 2301 Series, to which this declaration relates, is in conformity with European Standard EN 55022, EN 61000 and EN 55024.

IC Statement

This Class B digital apparatus complies with Canadian ICES-003.

WEEE Statement

The European Union has established regulations for the collection and recycling of all waste electrical and electronic equipment (WEEE). Implementation of WEEE regulations may vary slightly by individual EU member states. Please check with your local and state government guidelines for safe disposal and recycling or contact your national WEEE recycling agency for more information.

Product Operation and Storage

Please read and follow all instructions provided with this product, and operate for intended use only. Do not attempt to open the product casing as this may cause damage and will void warranty. Use only the power supply provided with this product. When not in use, product should be stored in a dry location between -20°C and 70°C.

©2016 Icron Technologies Corporation. All rights reserved. Icron Technologies Corporation, the Icron Technologies Corporation logo, and the Icron Technologies Corporation products referred to herein are either the trademarks or the registered trademarks of Icron Technologies Corporation. All other trademarks are property of their respective owners. Icron Technologies Corporation assumes no responsibility for errors that may appear in this manual. Information contained herein is subject to change without notice.

Contents

Introduction	3
Product Contents	3
Features	3
The LEX Unit	4
The REX Unit.....	5
Installation Guide	6
Installing the Ranger 2301 Series as Direct Connect.....	6
Requirements	6
Preparing Your Site	6
Installing the LEX	7
Connecting the LEX to the REX	7
Installing the REX	7
Local Area Network Installation (2301GE-LAN model only)	8
Requirements	8
Preparing Your Network.....	8
Preparing Your Site	9
Installing the LEX	9
Installing the REX	9
Checking the Installation.....	10
Connecting a USB Device.....	11
Pairing the LEX and REX (2301GE-LAN model only).....	11
Unpairing an Extender	11
Compatibility	11
Optional USB Extender Mounting Options	12
Option 1: USB Extender Mounting Kit	12
Option 2: USB Extender Direct Surface Mounting	13
Option 3: Cable-Tie Mounting	13
Troubleshooting	14
Warranty Information	16
Obtaining Warranty Service	16
Contacting Technical Support	17
Technical Glossary	18
Specifications.....	19

Introduction

This guide provides product information for the USB 2.0 Ranger® 2301 Series (2301 and 2301GE-LAN models), installation instructions and troubleshooting guidelines. The instructions in this guide assume a general knowledge of computer installation procedures, familiarity with cabling requirements and some understanding of USB devices.

 **NOTE:** Notes provide additional information that could be useful.

 **CAUTION:** Cautions provide important information about an operational requirement.

Ranger 2301/2301GE-LAN Product Contents

Your Ranger 2301 Series extender system contains:

- LEX (Local Extender)
- REX (Remote Extender)
- USB 2.0 Cable
- REX AC International Power Adapter
- Country Specific Power Cable
- Quick Start Guide

Features

The Ranger 2301 Series incorporates ExtremeUSB® technology, enabling users to extend USB beyond the standard 5m cable limit for USB 2.0 peripheral devices. The Ranger 2301/2301GE-LAN extender system is composed of two individual units, the LEX and the REX, and has the following key features:

- 100m of extension when directly connected over CAT 5e/6/7
- Support for new USB 3.0 host controllers and devices (up to 480 Mbps)
- Support for all device USB types
- USB extension over a Gigabit Ethernet Local Area Network (LAN) for 2301GE-LAN model

The Ranger 2301 Series includes the ExtremeUSB® suite of features:



- Transparent USB extension
- True plug and play; no software drivers required
- Works with all major operating systems: Windows®, OS X® and Linux®

 **NOTE:** USB 3.0 devices will perform at USB 2.0 speeds if extended through the RG2301 Series extender.

The LEX Unit

The LEX unit connects to the computer using a standard USB 2.0 cable. Power for this unit is provided by the host computer.

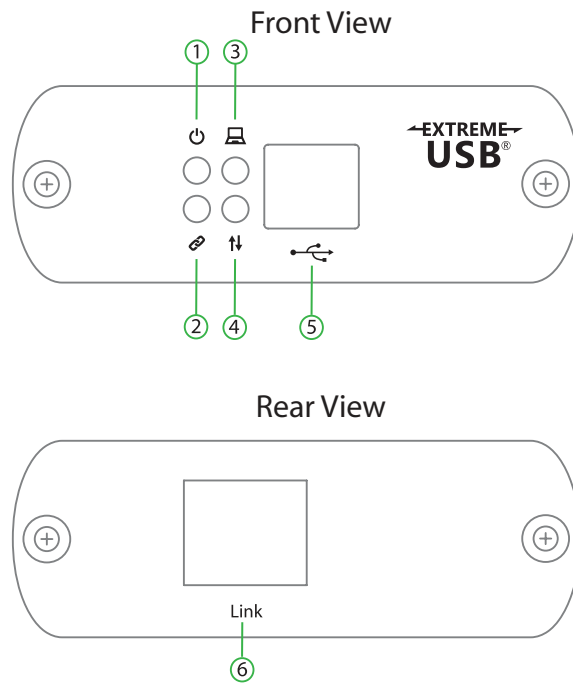

ITEM	TYPE	DESCRIPTION
1	Power LED (Green) ⏻	LED turns on when power is supplied. LED is off when no power is supplied by the host computer.
2	Link LED (Green) 🔗	Indicates a valid ExtremeUSB link is established between the LEX and REX. LED turns on when link between the LEX and REX is established. LED is off when there is no link between LEX and REX units. LED is slow blinking when the unit is attempting to establish a link. LED is fast blinking to indicate the unit is in Pairing Mode.
3	Host LED (Green) 💻	Indicates that the extender system is properly enumerated on the host computer. LED blinks when the extender system is in a suspended state.
4	Activity LED (Green) ↕	Indicates data transmission is occurring between the LEX and REX. LED blinks intermittently with or without a USB device connected. When the LEX and REX units are in suspend mode, the LED is off.
5	USB Host Port	Used to connect the LEX to the host computer. Accepts USB Type B connector.
6	Link Port (RJ45) 🔌	Accepts RJ45 connector for CAT 5e/6/7 cabling to connect the LEX to the REX unit.

The REX Unit

The REX unit provides one USB Type A port for standard USB devices and allows you to connect one USB device directly. Additional devices may be connected by attaching up to four USB hubs to the REX unit. The REX is powered by an external AC adapter, supplying up to 1 Amp to the USB port.

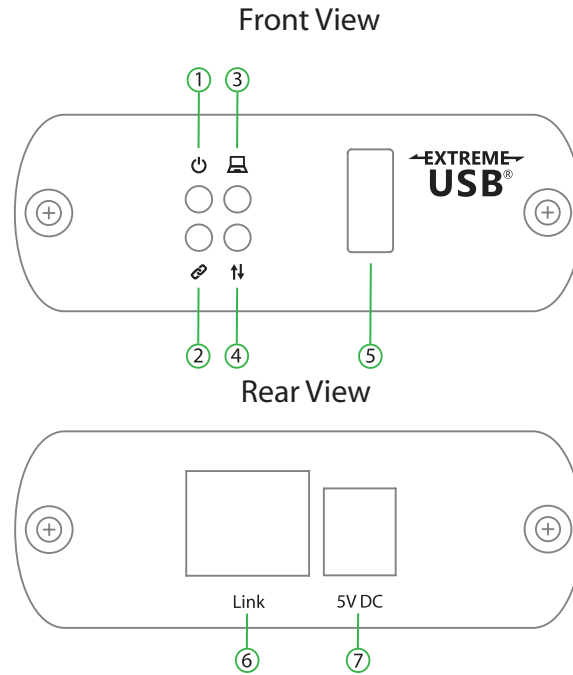

ITEM	TYPE	DESCRIPTION
1	Power LED (Green) ⏻	LED turns on when power is supplied.
2	Link LED (Green) 🔗	Indicates a valid ExtremeUSB link is established between the LEX and REX. LED turns on when link between LEX and REX is established. LED is off when there is no link between LEX and REX units. LED is slow blinking when the unit is attempting to establish a link. LED is fast blinking to indicate the unit is in Pairing Mode.
3	Host LED (Green) 💻	Indicates that the extender system is properly enumerated on the host computer. LED blinks when the extender system is in a suspended state.
4	Activity LED (Green) ↕	Indicates data transmission is occurring between LEX and REX. LED blinks intermittently with or without a USB device connected. When the LEX and REX units are in suspend mode, the LED is off.
5	USB Device Port	Accepts USB device using Type A connector.
6	Link Port (RJ45)	Accepts RJ45 connector for CAT 5e/6/7 cabling to connect the LEX to the REX unit.
7	Power Port	Connects to the AC power supply.

Installation Guide

Installing the Ranger 2301 Series as Direct Connect

Requirements

To complete the installation, you will also require the following items that are not included with this system:

- USB compatible computer (host computer) with a USB compliant operating system
- USB compatible device(s)
- CAT 5e/6/7 Unshielded Twisted Pair (UTP) cable with two RJ45 connectors (if using surface cabling), or, CAT 5e/6/7 cabling with two information outlets and two CAT 5e/6/7 patch cords with RJ45 connectors (if using premise cabling)

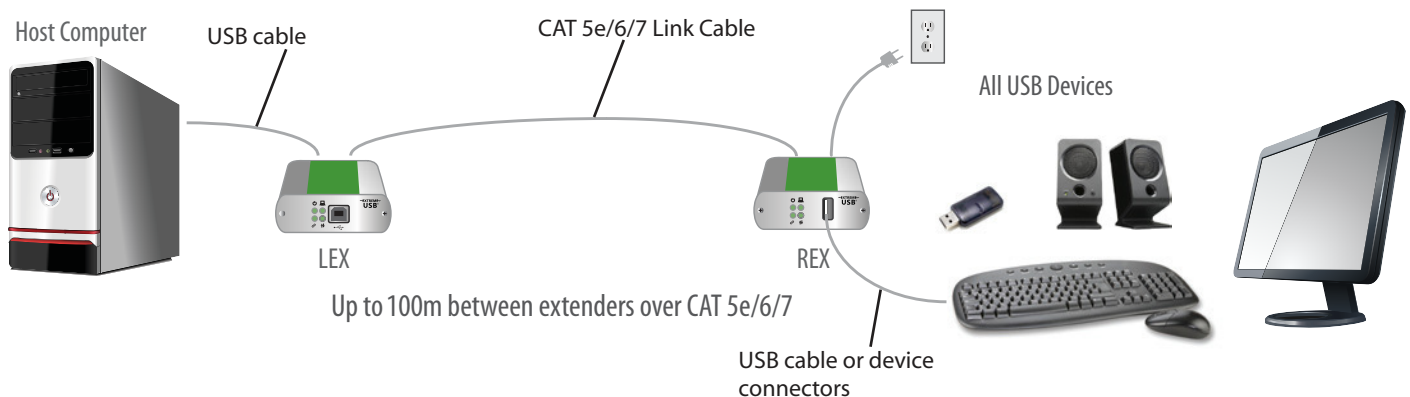

Preparing Your Site

Before installing the Ranger 2301 Series extender, you will need to prepare your site:

1. Place the computer where desired and set it up.
2. Ensure to locate the USB device(s) within 100m cable-length of the computer. If not, adjust the location of the devices and/or computer accordingly.
3. If you are using surface cabling, install the CAT 5e/6/7 cabling as desired and terminate it with the appropriate RJ45 ends.
4. If using premise cabling (in-building network infrastructure), ensure your cabling does not exceed 100m and that it meets CAT 5e/6/7 specification.

! Cable installation is important, particularly if high throughput applications are used. When installing, ensure the cable is installed away from or isolated from potential sources of interference such as electrical wiring, fluorescent lighting, etc.



When terminating cables, ensure the matching RJ45 connector is used for the cable type. For example, if CAT 6 cable is used, then CAT 6 compatible RJ45 connectors must be used. If this care is not taken, the benefits of higher grade cabling may not be realized.

Installing the LEX

1. Place the LEX near the computer.
2. Connect the supplied USB cable between the LEX host port and a USB port on the host computer.

Connecting the LEX to the REX

With Surface Cabling:

1. Connect the CAT 5e/6/7 cable into the Link port of the LEX.
2. Connect the CAT 5e/6/7 cable into the Link port of the REX.

With Premise Cabling:

1. Connect a CAT 5e/6/7 patch cable (not provided) into the information outlet near the host computer.
2. Connect the patch cable into the Link port of the LEX.
3. Connect a CAT 5e/6/7 patch cable (not provided) into the information outlet near the USB devices.
4. Connect the patch cable into the Link port of the REX.

Installing the REX

1. Place the REX near the USB device.
2. Assemble the power adapter and country specific power cord together and connect them into a suitable AC outlet.
3. Connect the power adapter to the REX.

Local Area Network Installation (2301GE-LAN model only)

Requirements

To complete the installation, you will also require the following items that are not included with this system:

- USB compatible computer (host computer) with a USB compliant operating system
- USB compatible device(s)
- Two CAT 5e/6/7 patch cables
- Preconfigured Local Area Network

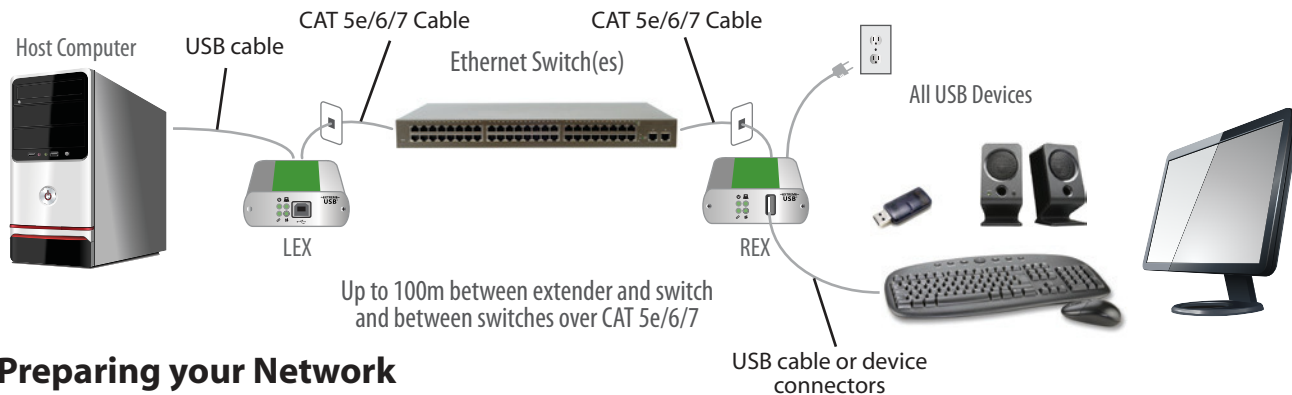

Preparing your Network

Your network must be properly configured in order for full USB 2.0 throughput to be realized and for maximum stability and reliability of your devices. Consult with your network administrator prior to installation. Using the Ranger 2301GE-LAN over a network requires:

- LEX and REX to be on the same subnet
- RJ45 information outlets to be near the computer and USB devices to be connected to the network switch(es)
- Pre-installed and configured Local Area Network

! USB 2.0 is capable of consuming up to 480 Mbps. The minimum requirement for using the Ranger 2301GE-LAN is a Gigabit (1000Base-T) network. The performance of the USB network extension will be limited to the slowest link between the LEX and REX.

! Some networks may be configured to block devices with unfamiliar MAC addresses. If this is the case, you will need to provide your network administrator the MAC addresses of the LEX and REX units. These can be found on the label on the bottom of each unit.

! Some networks may be configured to block devices that consume a consistently high level of bandwidth. The Ranger 2301GE-LAN may exhibit this behaviour when high bandwidth devices are connected. Consult with your network administrator to resolve this issue.

note Units will be pre-paired with each other if they were sold together in the same box. If they are not paired, follow the instructions provided in the section for pairing a LEX and REX.

note Increasing the number of switches between the LEX and REX may reduce the available bandwidth and as a result prevent some devices from functioning properly.

note Only the Ranger 2301GE-LAN model will connect and extend over a LAN. The 2301 model is point-to-point direct connect over CAT 5e/6/7 only.

Preparing Your Site

Before installing the Ranger 2301GE-LAN, you will need to prepare your site:

1. Place the computer where desired and set it up.
2. Ensure to locate the USB device(s) within 100m of CAT 5e/6/7 cabling of the switch.
3. Ensure to locate the computer within 100m of CAT 5e/6/7 cabling of the switch.



The cable distance between switches must be no greater than 100m.

Installing the LEX

1. Place the LEX near the computer.
2. Connect the supplied USB cable between the LEX host port and a USB port on the host computer.
3. Connect a CAT 5e/6/7 patch cable (not provided) into the information outlet near the host computer and then connect the patch cable into the Link port of the LEX.

Installing the REX

1. Place the REX near the USB device(s).
2. Assemble the power adapter and country specific power cord together and connect them into a suitable AC outlet.
3. Connect the power adapter to the REX.
4. Connect a CAT 5e/6/7 patch cable (not provided) into the information outlet near the USB device(s).
5. Connect the patch cable into the Link port of the REX.

Checking the Installation

1. On the LEX and REX, check that the Power, Activity, Link and Host LEDs are on.
 - **For direct connect**, if the Host or Link LEDs are permanently off, then the cabling between the LEX and REX may not be installed properly or is defective.
 - **For network connect (2301GE-LAN model only)**, if the Link LED is blinking, then the network connection between the LEX and REX is not complete and there may be faulty cabling, network components, misconfigured network components, or the LEX and REX may need to be re-paired together (see the section on pairing a LEX and REX).
2. For Windows users (XP, 7, 8, 8.1, 10), open Device Manager to confirm that the Ranger 2301 Series extender system has been installed correctly. Expand the entry for Universal Serial Bus controllers by clicking the “+” sign. If the extender system has been installed correctly, you should find it listed as a “Generic USB Hub”.



To open Device Manager in Windows XP:

Right click “My Computer” then select: Properties >> Hardware tab >> Device Manager



To open Device Manager in Windows 7:

Open the Start Menu, right click on “Computer” then select: Manage >> Device Manager



To open Device Manager in Windows 8, 8.1 or 10:

Right click the Start Menu and then select: Device Manager

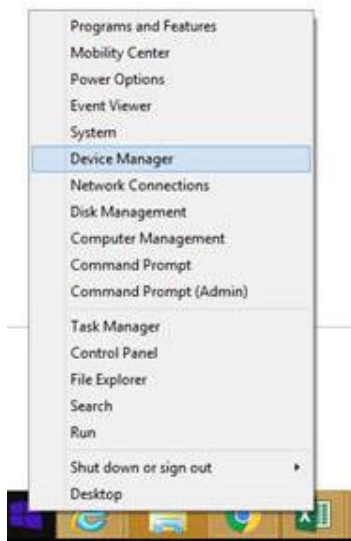

3. For OS X users, open the System Profiler to confirm that the Ranger 2301 Series extender system has been installed correctly. In the left hand column under Hardware, select “USB” and inspect the right hand panel. If the extender has been installed correctly, you should find it listed as a “Hub” under the USB High-Speed Bus/USB Bus.



To open System Profiler in OS X:

Open the Finder, select Applications, then open the Utilities folder and double click on the System Profiler icon.

4. If the Ranger 2301 Series extender system is not detected correctly or fails to detect, please consult the Troubleshooting section in this guide.

Connecting a USB Device

1. Install any software required to operate the USB device. Refer to the documentation for the USB device, as required.
2. Connect the USB device to the device port on the REX.
3. Check that the device is detected and installed properly in the operating system.

Pairing the LEX and REX (2301GE-LAN model only)

When bought as a complete system that consists of both a LEX and REX, the Ranger 2301GE-LAN extender will be paired with each other out of the box, so no pairing action should be required. However, if extenders are bought individually, or you simply wish to change the LEX and REX pairings across a network, then the following steps must be taken:

! The following steps apply to both direct connect and network connect configurations for the Ranger 2301GE-LAN.

1. Ensure the LEX and REX units are either directly connected to each other, or are connected to the same subnet on your network.
2. Press and hold the Mode button on the bottom of the LEX. Release the button within 10 seconds. The Link LED will start flashing. Pairing mode has been activated on the LEX.
3. Within 10 minutes of activating the pairing mode on the LEX, press and hold the Mode button on the bottom of the REX. Release the button within 10 seconds. The Link LED will start flashing. Pairing mode has been activated on the REX.
4. The Link LED on both units may start flashing more slowly before finally turning on. Once the Link LEDs are solid, the link is established between both extenders.

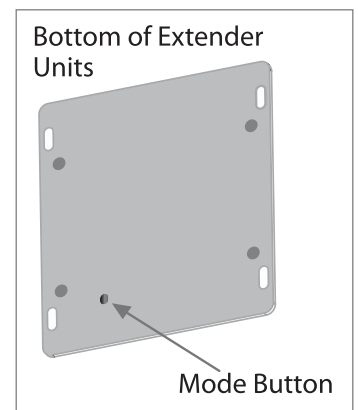

note If more than 10 minutes passes before the units are paired, then the extenders will switch back to regular mode and reestablish the previous links they had, if any.

note To cancel pairing mode, press and hold the 'Mode' button a second time. Release it within 10 seconds.

Unpairing an Extender

If for any reason an extender needs to have its pairing removed, this can be done by pressing and holding the Mode button for longer than 10 seconds. Once this is completed the unit will not be paired to any other extender.

Compatibility

The USB 2.0 Ranger 2301 Series complies with USB 1.1 and USB 2.0 specifications governing the design of USB devices. However, there is no guarantee that all USB devices or hosts will be compatible as there are a number of different characteristics that may impact the operation of USB devices over extended distances.

Optional USB Extender Mounting Options

The bottom of the Ranger 2301 Series enclosures feature four convenient pre-drilled holes for optional direct surface mounting and four mounting slots for easy cable-ties. Based on your requirements, choose from three available mounting options:

1. **USB Extender Mounting Kit**
2. **USB Extender Direct Surface Mounting**
3. **USB Extender Cable-Tie Mounting**

Option 1: USB Extender Mounting Kit

Order Part #10-00535 USB Mounting Kit (2301/12) - Silver (Available for purchase separately)

1 kit required to mount per LEX or REX

Each kit includes:

- 2 mounting brackets
- 4 (M2.5) locking washers
- 4 (M2.5 x 7.0mm) Phillips pan head screws
- Mounting bracket installation guide (*see diagram below*)

Using a Phillips screwdriver, in the order as illustrated below, fasten and secure the provided screws, locking washers and brackets into place.

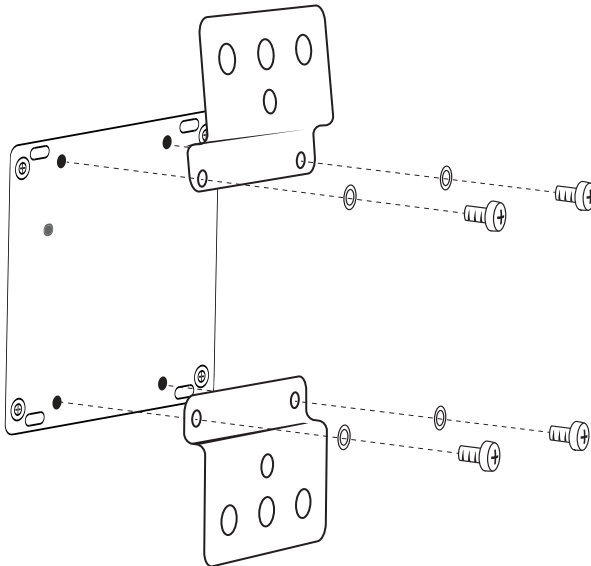

Option 2: USB Extender Direct Surface Mounting (using your own hardware)

The bottom of the Ranger 2301 Series enclosures feature four pre-drilled holes for optional direct surface mounting. Using the stencil below, along with your own hardware you can directly mount your USB Extender on a surface.

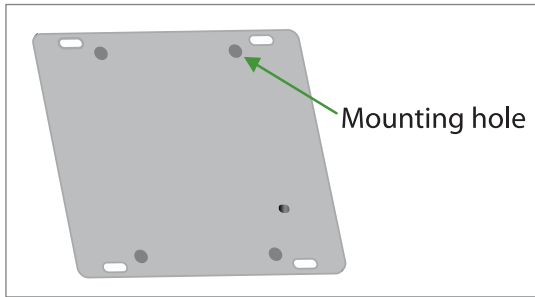

Distance between the enclosure mounting holes:
42.00 x 62.53mm

1. Mark the center point of each of the four holes on your mounting surface either by directly measuring or using a print out of the stencil below.
2. Hardware recommendation: M2.5 locking washers and M2.5 screws (4 of each per extender) noting screw length will depend upon thickness of mounting surface.
3. Drill through each of the four hole markings on the mounting surface using a 3.70mm (0.1457") drill bit.
4. Align the bottom enclosure holes to the newly drilled out holes on the mounting surface.
5. Place a locking washer on each of the four screws and using a screwdriver, fasten the extender into place.



To ensure the stencil below prints to scale be sure to set the page scaling setting to "none".

Direct Surface Mounting Measurement Stencil

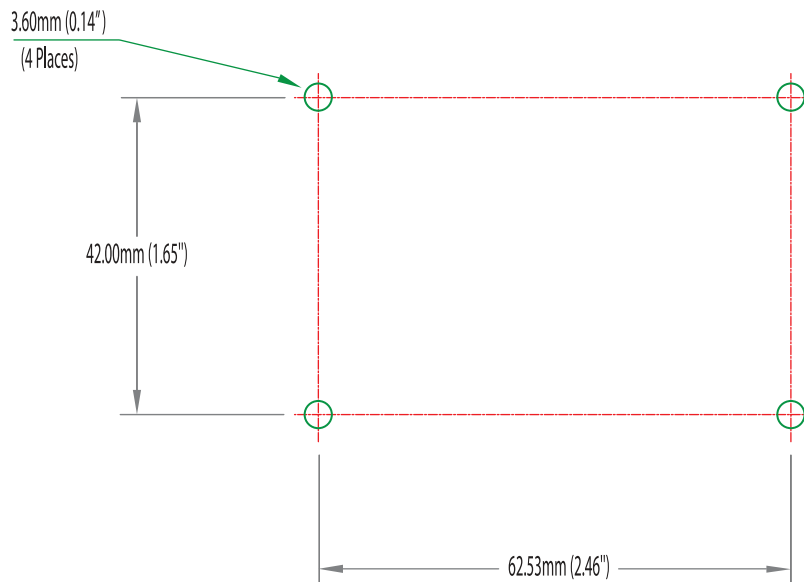

Option 3: Cable-Tie Mounting

The bottom of the Ranger 2301 Series enclosure also features four convenient slots for cable mounting. Simply thread a cable tie, (also called tie-wrap or zip tie), into the mounting slot and through the cable tie head, and secure it to a pole or other surface by pulling it tight. Cable ties are not included with this system due to varying lengths dependent upon the application.

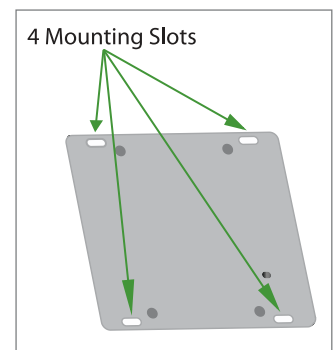

Troubleshooting

The following table provides troubleshooting tips. The topics are arranged in the order in which they should be executed in most situations. If you are unable to resolve the problem after following these instructions, please contact Icron Technologies' [Technical Support](#) for further assistance.

PROBLEM	CAUSE	SOLUTION
All LEDs on the LEX are off.	<ul style="list-style-type: none"> The LEX is not receiving power from the USB port. 	<ol style="list-style-type: none"> Ensure that the host computer is connected to the LEX. Move the USB connector to another USB port on the host computer.
All LEDs on the REX are off.	<ul style="list-style-type: none"> The REX is not receiving power from the AC adapter. 	<ol style="list-style-type: none"> Ensure that the AC power adapter is properly connected to the REX. Check that the AC adapter is connected to a live source of electrical power. Check that the REX's power LED is illuminated.
Link LEDs on the LEX and REX are off.	<ul style="list-style-type: none"> There is no connection between the LEX and REX. 	<ol style="list-style-type: none"> Ensure the CAT 5e/6/7 cable is connected between the LEX and REX units; cable should be UTP or STP, with a straight through connector and no crossovers, and 8 conductor RJ45 connectors are used at both ends. Connect a short CAT 5e/6/7 patch cord between the LEX and REX to determine if the original CAT 5e/6/7 cable is defective.
Link LEDs are blinking.	<ul style="list-style-type: none"> There is no connection between the LEX and REX. Units may not be paired to each other. Network switches exist on different subnets. Network switch(es) are blocking traffic from the extenders. 	<ol style="list-style-type: none"> Ensure both the LEX and REX are connected together directly or are connected to active network switches. Re-pair the units together. Ensure the network switches can communicate with each other and are on the same subnet. Ensure the network switches are not blocking traffic from the extenders either based on MAC address or due to traffic patterns. Consult with your network administrator.

PROBLEM	CAUSE	SOLUTION
Link LED on the LEX and REX are blinking slowly.	<ul style="list-style-type: none"> • The extenders are paired with each other but have not yet established a link. 	<ol style="list-style-type: none"> 1. Wait for a few minutes for the LEDs to go solid. 2. If LEDs do not go solid, contact your network administrator to determine if any traffic is being blocked between the extenders.
Link LED on the LEX is on, Host LED on the LEX is off.	<ul style="list-style-type: none"> • The host computer is not powered on. • The LEX is not connected to the computer. • The host computer is not recognizing the LEX. • The computer does not support USB hubs. • The extender system is malfunctioning. 	<ol style="list-style-type: none"> 1. Disconnect the USB device from the REX. 2. Disconnect the LEX from the computer. 3. Disconnect the REX from the AC power adapter. 4. Reconnect the LEX to the computer. 5. Reconnect the REX to the AC power adapter. 6. In the Universal Serial Bus controllers section of Device Manager, check that the extender system is recognized as a "Generic USB Hub".
My USB device does not work properly.	<ul style="list-style-type: none"> • Insufficient bandwidth is available on the network to support the device. 	<ol style="list-style-type: none"> 1. Connect the LEX and REX directly to each other and try the USB device again.
My USB device does not work at all.	<ul style="list-style-type: none"> • Insufficient bandwidth is available on the network to support the device. • The LEX is paired to the wrong REX. 	<ol style="list-style-type: none"> 1. Connect the LEX and REX directly to each other and try the USB device again. 2. Follow the instructions on page 11 and pair the LEX to the REX that is connected to the device you wish to use.

Warranty Information

Limited Hardware Warranty

Icron Technologies Corporation warrants that any hardware products accompanying this documentation shall be free from significant defects in material and workmanship for a period of **two years from the date of purchase**. Icron Technologies Corporation's hardware warranty extends to Licensee, its customers and end users.

The Warranty does not include repair of failures caused by: misuse, neglect, accident, modification, operation outside a normal operating environment, failure caused by service of the device by non-authorized servicers, or failure caused by a product for which Icron Technologies Corporation is not responsible. Opening the enclosures will void warranty.

Hardware Remedies

Icron Technologies Corporation's entire liability and the Licensee's exclusive remedy for any breach of warranty shall be, at Icron Technologies Corporation's option, either (a) return of the price paid or (b) repair or replacement of hardware; which will be warranted for the remainder of the original warranty period or 30 days, whichever is longer. These remedies are void if failure of the hardware has resulted from accident, abuse, or misapplication.

Limitation of Liability

The hardware warranty set forth in this agreement replaces all other warranties. Icron Technologies Corporation expressly disclaims all other merchantability and fitness for a particular purpose and noninfringement of third-party rights with respect to the hardware.

Icron Technologies Corporation dealer, agent, or employee is not authorized to make any modification extension or addition to this warranty. Under no circumstances will Icron Technologies Corporation, its suppliers or licensors be liable for any costs of procurement or substitute products or services, lost profits, loss of information or data, or any other special, indirect, consequential, or incidental damages arising in any way out of the sale of, use of, or inability to use Icron Technologies Corporation product or service, even if Icron Technologies Corporation, its suppliers or licensors have been advised of the possibility of such damages. In no case shall Icron Technologies Corporation, its suppliers and licensors' liability exceed the actual money paid for the products at issue.

Since some jurisdictions do not allow the limitation of implied warranties of liability for incidental, consequential, special or indirect damages, the above limitation may not always apply. The above limitation will not apply in case of personal injury where and to the extent that applicable law requires such liability.

Obtaining Warranty Service

To obtain warranty service, you must first contact Icron Technologies Corporation within the warranty period for a Return Material Authorization (RMA) number. Icron Technologies Corporation will not accept returns without an authorized RMA number. Prior to contacting Icron Technologies Corporation, be sure you have recorded the serial numbers of the LEX and REX. Package the product appropriately for safe shipment and mark the RMA number on the outside of the package. The package must be sent prepaid to Icron Technologies Corporation. We recommend that you insure it or send it by a method that provides for tracking of the package. The repaired or replaced item will be shipped to you, at Icron Technologies Corporation's expense, not later than thirty days after Icron Technologies Corporation receives the defective product.

Contacting Technical Support

If you are experiencing problems not referenced in the Troubleshooting section, contact **Icron Technical Support**:

www.icron.com/support

Tel: +1 604 638 3939

To help us serve you better, please include the following information with your technical support request:

- Host computer make and model
- Type of Operating System installed (e.g. Windows 10, OS 10.11, etc.)
- Part number and serial number for both the LEX and REX
- Make and model of any USB device(s) attached to the product
- Description of the installation
- Description of the problem
- Description of the network (e.g. number of switches, switch model names, switch speeds, etc.)

Address the returned product to:

RMA Coordinator
Icron Technologies Corporation
4664 Lougheed Highway, Suite 221
Burnaby, BC Canada
V5C 5T5

Contacting Sales

Email: sales@icron.com

Tel: +1 604 638 3920

Technical Glossary

Category 5e/6/7 (CAT 5e/6/7) Network Cabling

Category 5e/6/7 cable is commonly also referred to as CAT 5e or CAT 6 or CAT 7. This cabling is available in either solid or stranded twisted pair copper wire variants and as UTP (Unshielded Twisted Pair) or STP (Shielded Twisted Pair). UTP cables are not surrounded by any shielding making them more susceptible to Electromagnetic Interference (EMI). STP cables include shielding the copper wires and provides better protection against Electromagnetic Interference (EMI).

USB 2.0 Cables

USB 2.0 cables have two distinct full-sized connectors. The Type A connector is used to connect the cable from a USB device to the Type A port on a computer or hub. The Type B connector is used to attach the USB cable to a USB device.

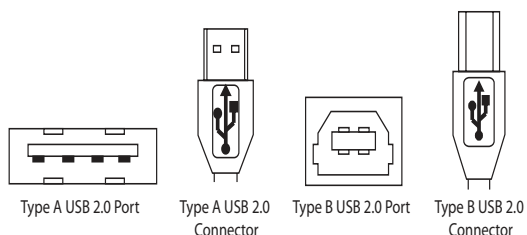

RJ45

The Registered Jack (RJ) physical interface is what connects the network cabling (CAT 5e/6/7) to the LEX and REX. You may use either the T568A scheme (Table 1) or the T568B scheme (Table 2) for cable termination as the Ranger 2301 Series requires all four pairs of the cable. RJ45 connectors are sometimes also referred to as 8P8C connectors. Note that any given cable must be terminated using the same T568 scheme on both ends to operate correctly.

RJ45 Pin Positioning

Table 1 - T568A Wiring

PIN	PAIR	WIRE	CABLE COLOR
1	3	1	WHITE/GREEN
2	3	2	GREEN
3	2	1	WHITE/ORANGE
4	1	2	BLUE
5	1	1	WHITE/BLUE
6	2	2	ORANGE
7	4	1	WHITE/BROWN
8	4	2	BROWN

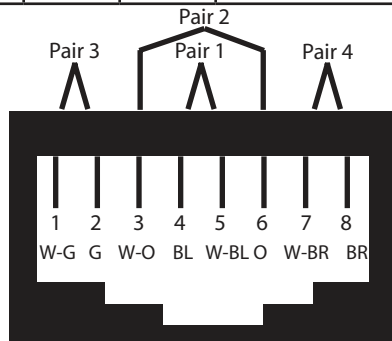
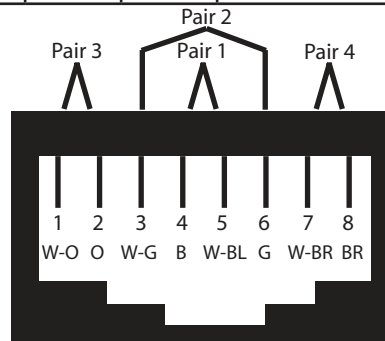

Table 2 - T568B Wiring

PIN	PAIR	WIRE	CABLE COLOR
1	2	1	WHITE/ORANGE
2	2	2	ORANGE
3	3	1	WHITE/GREEN
4	1	2	BLUE
5	1	1	WHITE/BLUE
6	3	2	GREEN
7	4	1	WHITE/BROWN
8	4	2	BROWN



Specifications

RANGE	
Direct Connect	Up to 100m (330 ft) over solid core CAT 5e/6/7
Network Connect	Up to 100m (330 ft) between switches over solid core CAT 5e/6/7
USB DEVICE SUPPORT	
Maximum Throughput	Up to 480 Mbps*
Traffic Types	All Traffic Types
Device Types	All Device Types
Maximum Number	Up to 30 devices
NETWORKING (2301GE-LAN model only)	
Standards	1000BASE-T
Data Traffic	Layer 2
Control Traffic (2301GE-LAN model only)	Layer 3, customizable as unicast or broadcast
LOCAL EXTENDER (LEX)	
USB Connector	1 x USB 2.0 Type B Receptacle
Link Connector	1 x RJ45
Dimensions	86.0mm x 75.0mm x 26.0mm (3.4" x 3.0" x 1.0")
Enclosure Material	Silver Anodized Aluminum
REMOTE EXTENDER (REX)	
USB Connector	1 x USB 2.0 Type A Receptacle
Link Connector	1 x RJ45
Dimensions	86.0mm x 75.0mm x 26.0mm (3.4" x 3.0" x 1.0")
Enclosure Material	Silver Anodized Aluminum
Available Current	Up to 1 Amp
Power Supply	100-240V AC input, 5V 3A DC Output
ENVIRONMENTAL	
Operating Temperature Range	0°C to 50°C (32°F to 122°F)
Storage Temperature Range	-20°C to 70°C (-4°F to 158°F)
Operating Humidity	20% to 80% relative humidity, non-condensing
Storage Humidity	10% to 90% relative humidity, non-condensing
COMPLIANCE	
EMC	FCC (Class B), CE (Class B)
Environmental	RoHS2 (CE)
SUPPORT	
Warranty	2-year

* Maximum speed is heavily dependant on network configuration, bandwidth and performance.



Icron Technologies Corporation
4664 Lougheed Highway, Suite 221
Burnaby, BC Canada
V5C 5T5

Tel: +1 604 638 3920

Fax: +1 604 638 3930

www.icron.com