

# USB 2.0 RG2304 Network Series

4-Port USB 2.0 Gigabit Ethernet LAN  
Extender Systems

## User Guide



Thank you for purchasing the USB 2.0 RG2304N, 2304S or 2304GE-LAN.

Please read this guide thoroughly.

This document applies to the following part numbers:

Model	NA System	EU System	UK System	AU System	JP System	Local Extender Turnkey PCBA	Remote Extender Turnkey PCBA	Local Extender Module	Remote Extender Module
<b>RG2304N</b> Direct Connect +LAN	01-00609	01-00610	01-00611	01-00612	01-00613	02-00117	02-00118	10-00531	10-00532
<b>RG2304GE-LAN</b> Direct Connect +LAN + SwitchableUSB™	01-00453	01-00454	01-00455	01-00456	01-00529	02-00030	02-00031	10-00533	10-00534
<b>RG2304S</b> Direct Connect +LAN + SwitchableUSB™ + Simultaneous Users Interaction	-	-	-	-	-	02-00149	02-00150	10-00538	10-00539

### FCC Radio Frequency Interference Statement Warning

This device complies with Part 15 of the FCC rules. Operation is subject to the following two conditions: (1) this device may not cause harmful interference, and (2) this device must accept any interference received including interference that may cause undesired operation.

### CE Statement

We, Icron Technologies Corporation, declare under our sole responsibility that the USB 2.0 RG2304 Series, to which this declaration relates, is in conformity with European Standard EN 55022, EN 61000 and EN 55024.

### IC Statement

This Class B digital apparatus complies with Canadian ICES-003.

### WEEE Statement

The European Union has established regulations for the collection and recycling of all waste electrical and electronic equipment (WEEE). Implementation of WEEE regulations may vary slightly by individual EU member states. Please check with your local and state government guidelines for safe disposal and recycling or contact your national WEEE recycling agency for more information.

### Product Operation and Storage

Please read and follow all instructions provided with this product, and operate for intended use only. Do not attempt to open the product casing as this may cause damage and will void warranty. Use only the power supply provided with this product (if applicable). When not in use, product should be stored in a dry location between -20°C and 70°C.

# Contents

<b>Introduction</b> .....	<b>3</b>
RG2304N/2304S/2304GE-LAN Product Contents.....	3
Features .....	3
The Local Extender .....	4
The Remote Extender .....	5
<b>Installation Guide</b> .....	<b>6</b>
Installing the RG2304N, 2304S or 2304GE-LAN System on a Local Area Network.....	6
Requirements .....	6
Preparing your Network .....	6
Preparing Your Site .....	7
Installing the Local Extender .....	7
Installing the Remote Extender .....	7
Installing the RG2304N, 2304S or 2304GE-LAN System as Direct Connect.....	8
Requirements .....	8
Preparing Your Site .....	8
Installing the Local Extender .....	9
Connecting the Local Extender to the Remote Extender .....	9
Installing the Remote Extender .....	9
Checking the Installation.....	10
Connecting a USB Device.....	11
Pairing the Local and Remote Extender.....	11
Unpairing an Extender .....	11
Compatibility .....	11
<b>USB Extender Mounting Options</b> .....	<b>12</b>
Option 1: USB Extender Mounting Kit .....	12
Option 2: USB Extender Direct Surface Mounting .....	13
<b>Troubleshooting</b> .....	<b>14</b>
<b>Contacting Technical Support</b> .....	<b>16</b>
<b>Technical Glossary</b> .....	<b>17</b>
<b>Specifications</b> .....	<b>18</b>

## Introduction

This guide provides product information for the USB 2.0 RG2304 Series, installation instructions and troubleshooting guidelines. The instructions in this guide assume a general knowledge of computer installation procedures, familiarity with cabling requirements and some understanding of USB devices.

 NOTE: Notes provide additional information that could be useful.

 CAUTION: Cautions provide important information about an operational requirement.

## RG2304N/2304S/2304GE-LAN Product Contents

Your extender system is packaged with:

- Local Extender
- Remote Extender
- USB 2.0 Cable
- Remote Extender AC International Power Adapter
- Country Specific Power Cable
- Quick Start Guide

 The RG2304S model ships in bulk only, not as a kitted system.

## Features

The RG2304 Series incorporates ExtremeUSB® technology, enabling users to extend USB beyond the standard 5m cable limit for USB 2.0 peripheral devices. This extender system is composed of two individual units: the Local Extender and the Remote Extender and has the following key features:

- 100m of extension when directly connected over CAT 5e/6/7
- USB extension over a Gigabit Ethernet Local Area Network (LAN)
- Support for new USB 3.0 host controllers and devices
- Support for all USB device types

The RG2304 Series includes the ExtremeUSB® suite of features:

-  **←EXTREME→  
USB®**
- Transparent USB extension
  - True plug and play; no software drivers required
  - Works with all major operating systems: Windows®, macOS™ and Linux®

 USB 3.0 devices will perform at USB 2.0 speeds if extended through the RG2304 Series extender.

## The Local Extender

The local extender unit connects to the computer using a standard USB 2.0 cable. Power for this unit is provided by the host computer.

Front View

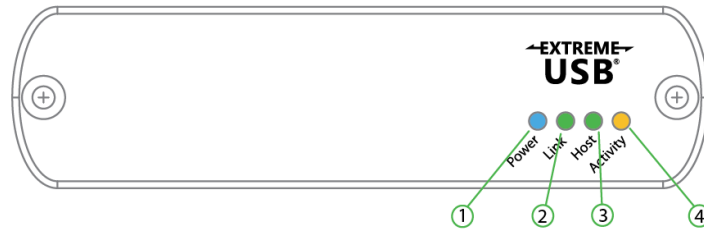

Rear View

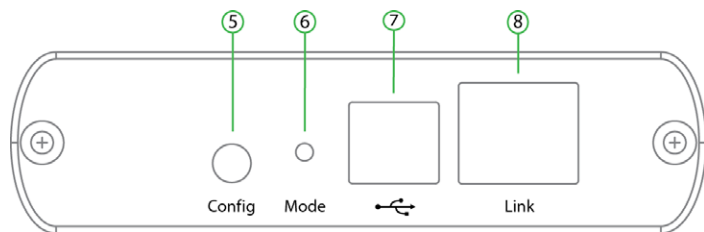

ITEM	TYPE	DESCRIPTION
1	Power LED (Blue)	LED turns on when power is supplied. LED is off when no power is supplied by the host computer.
2	Link LED (Green)	Indicates a valid ExtremeUSB link is established between the local and remote extender. LED turns on when link between local and remote extender is established. LED is off when there is no link between local and remote extenders. LED is slow blinking when the unit is attempting to establish a link. LED is fast blinking to indicate the unit is in Pairing Mode.
3	Host LED (Green)	Indicates that the extender system is properly enumerated on the host computer. The LED blinks when the extender is in a suspended state.
4	Activity LED (Amber)	Indicates data transmission is occurring between local and remote extenders. LED blinks intermittently with or without a USB device connected. When the local and remote extenders are in suspend mode, the LED is off.
5	Config	Reserved for manufacturer use.
6	Mode	Used to establish a paired connection between local and remote extenders.
7	USB Host Port	Used to connect the local extender to the host computer. Accepts Type B connector into the local extender.
8	Link Port (RJ45)	Accepts RJ45 connector for CAT 5e/6/7 cabling to connect the local extender to the remote extender unit.

## The Remote Extender

The remote extender unit provides USB Type A ports for standard USB devices and allows you to connect up to four USB devices directly. Additional devices may be connected by attaching up to four USB hubs to the remote extender unit. The remote extender is powered by an external AC adapter and can supply up to 600mA to each USB port when all four ports are used concurrently; 1A per port when two or less are being used.

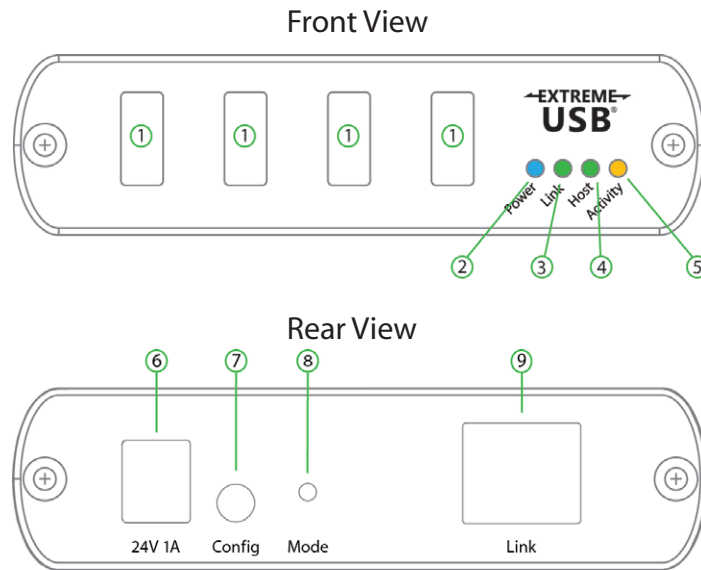

ITEM	TYPE	DESCRIPTION
1	USB Device Ports	Accepts USB device(s) using Type A connectors.
2	Power LED (Blue)	LED turns on when power is supplied. LED is off when no power is supplied by the host computer.
3	Link LED (Green)	Indicates a valid ExtremeUSB link is established between the local and remote extender. LED turns on when link between local and remote extender is established. LED is off when there is no link between local and remote extenders. LED is slow blinking when the unit is attempting to establish a link. LED is fast blinking to indicate the unit is in Pairing Mode.
4	Host LED (Green)	Indicates that the extender system is properly enumerated on the host computer. The LED blinks when the extender is in a suspended state.
5	Activity LED (Amber)	Indicates data transmission is occurring between local and remote extenders. LED blinks intermittently with or without a USB device connected. When the local and remote extenders are in suspend mode, the LED is off.
6	Power Port	Connects to the AC power supply. Required at the remote extender for proper operation.
7	Config	Reserved for manufacturer use.
8	Mode	Used to establish a paired connection between local and remote extenders.
9	Link Port (RJ45)	Accepts RJ45 connector for CAT 5e/6/7 cabling to connect the local extender to the remote extender unit.

# Installation Guide

## Installing the RG2304N, 2304S or 2304GE-LAN System on a Local Area Network

### Requirements

To complete the installation, you will also require the following items that are not included with this system:

- USB compatible computer (host computer) with a USB compliant operating system
- USB compatible device(s)
- Two CAT 5e/6/7 patch cables
- Preconfigured Local Area Network

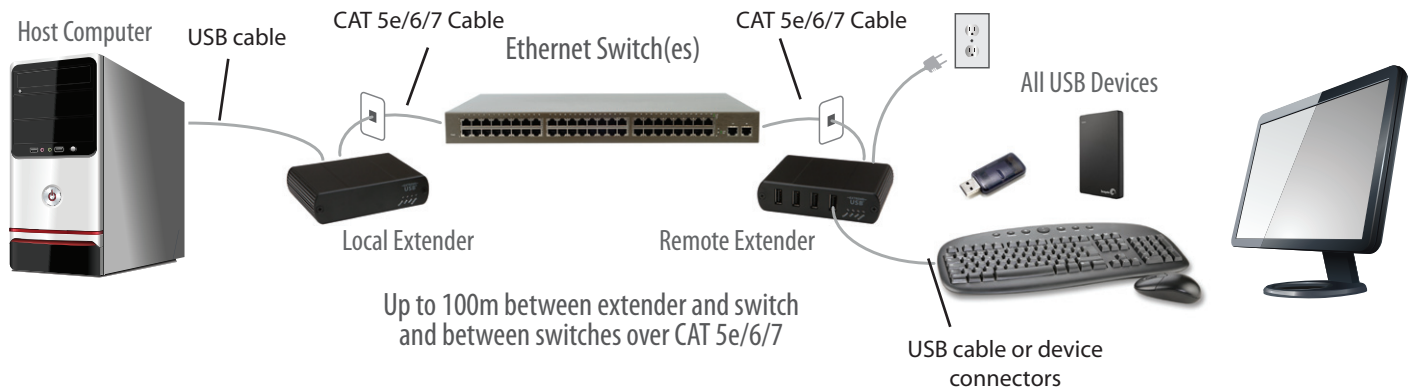

### Preparing your Network

Your network must be properly configured in order for full USB 2.0 throughput to be realized and for maximum stability and reliability of your devices. Consult with your network administrator prior to installation. Using the RG2304N, 2304S or 2304GE-LAN over a network requires:

- Local Extender and Remote Extender to be on the same subnet
- RJ45 information outlets to be near the computer and USB devices to be connected to the network switch(es)
- Pre-installed and configured Local Area Network

! USB 2.0 is capable of consuming up to 480Mbps. The minimum requirement for using the RG2304N/2304S/2304GE-LAN is a Gigabit (1000Base-T) network. The performance of the USB network extension will be limited to the slowest link between the local and the remote extender.

! Some networks may be configured to block devices with unfamiliar MAC addresses. If this is the case, you will need to provide your network administrator the MAC addresses of the local and remote extender units. These can be found on the label on the bottom of each unit.

! Some networks may be configured to block devices that consume a consistently high level of bandwidth. The RG2304N/2304S/2304GE-LAN may exhibit this behaviour when high bandwidth devices are connected. Consult with your network administrator to resolve this issue.

**note** Units will be pre-paired with each other if they were sold together in the same box as a system. If local and remote extender modules are purchased separately, in bulk or are not paired, follow the instructions provided in the section for pairing a local and remote extender.

**note** Increasing the number of switches between the local and remote extender may reduce the available bandwidth and as a result prevent some devices from functioning properly.

## Preparing Your Site

Before installing the RG2304N/2304S/2304GE-LAN, you will need to prepare your site:

1. Place the computer where desired and set it up.
2. Ensure to locate the USB device(s) within 100m of CAT 5e/6/7 cabling of the switch.
3. Ensure to locate the computer within 100m of CAT 5e/6/7 cabling of the switch.



The cable distance between switches must be no greater than 100m if CAT 5e/6/7 is used as the connection media.

## Installing the Local Extender

1. Place the local extender near the computer.
2. Connect the supplied USB cable between the local extender host port and a USB port on the host computer.
3. Connect a CAT 5e/6/7 patch cable (not provided) into the information outlet near the host computer.
4. Connect the patch cable into the Link port of the local extender.

## Installing the Remote Extender

1. Connect a CAT 5e/6/7 patch cable (not provided) into the information outlet near the USB devices.
2. Connect the patch cable into the Link port of the remote extender.
3. Place the remote extender near the USB device(s).
4. Assemble the power adapter and country specific power cord together and connect them into a suitable AC outlet.
5. Connect the power adapter to the remote extender.



# Installing the RG2304N, 2304S or 2304GE-LAN System as Direct Connect

## Requirements

To complete the installation, you will also require the following items that are not included with this system:

- USB compatible computer (host computer) with a USB compliant operating system
- USB compatible device(s)
- CAT 5e/6/7 Unshielded Twisted Pair (UTP) cable with two RJ45 connectors (if using surface cabling), or, CAT 5e/6/7 cabling with two information outlets and two CAT 5e/6/7 patch cords with RJ45 connectors (if using premise cabling)

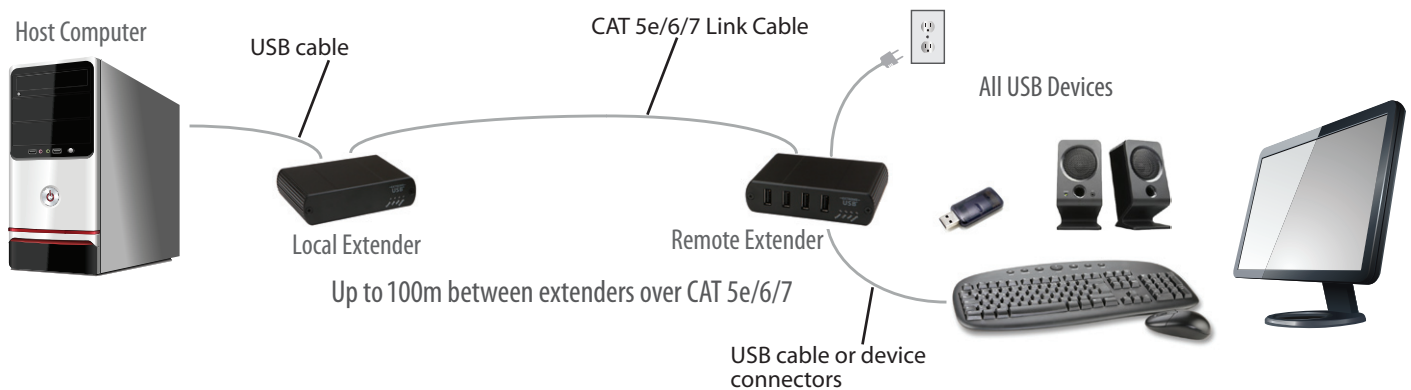

## Preparing Your Site

Before installing the RG2304N/2304S/2304GE-LAN, you will need to prepare your site:

1. Place the computer where desired and set it up.
2. Ensure to locate the USB device(s) within 100m cable-length of the computer. If not, adjust the location of the devices and/or computer accordingly.
3. If you are using surface cabling, install the CAT 5e/6/7 cabling as desired and terminate it with the appropriate RJ45 ends.
4. If using premise cabling (in-building network infrastructure), ensure your cabling does not exceed 100m and that it meets CAT 5e/6/7 specification.

- ! Cable installation is important, particularly if high throughput applications are used. When installing, ensure the cable is installed away from or isolated from potential sources of interference such as electrical wiring, fluorescent lighting, etc.



When terminating cables, ensure the matching RJ45 connector is used for the cable type. For example, if CAT 6 cable is used, then CAT 6 compatible RJ45 connectors must be used. If this care is not taken, the benefits of higher grade cabling may not be realized.

## **Installing the Local Extender**

1. Place the local extender near the computer.
2. Connect the supplied USB cable between the local extender host port and a USB port on the host computer.

## **Connecting the Local Extender to the Remote Extender**

### With Surface Cabling

1. Connect the CAT 5e/6/7 cable into the Link port of the local extender.
2. Connect the CAT 5e/6/7 cable into the Link port of the remote extender.

### With Premise Cabling

1. Connect a CAT 5e/6/7 patch cable (not provided) into the information outlet near the host computer.
2. Connect the patch cable into the Link port of the local extender.
3. Connect a CAT 5e/6/7 patch cable (not provided) into the information outlet near the USB devices.
4. Connect the patch cable into the Link port of the remote extender.

## **Installing the Remote Extender**

1. Place the remote extender near the USB device(s).
2. Assemble the power adapter and country specific power cord together and connect them into a suitable AC outlet.
3. Connect the power adapter to the remote extender.

## Checking the Installation

1. On the local and remote extender, check that the Power, Activity, Link and Host LEDs are on.
  - For direct connect, if the Host or Link LEDs are permanently off, then the cabling between the local and remote extender may not be installed properly or is defective.
  - For network connect, if the Link LED is blinking, then the network connection between the local and remote extender is not complete and there may be faulty cabling, network components, misconfigured network components, or the local and remote extender may need to be re-paired together (see the section on pairing a local and remote Extender).
2. For Windows users (XP, 7, 8, 8.1, 10), open Device Manager to confirm that the RG2304 Series extender system has been installed correctly. Expand the entry for Universal Serial Bus controllers by clicking the “+” sign. If the extender system has been installed correctly, you should find it listed as a “Generic USB Hub”.



To open Device Manager in Windows XP:

Right click “My Computer” then select: Properties >> Hardware tab >> Device Manager



To open Device Manager in Windows 7:

Open the Start Menu, right click on “Computer” then select: Manage >> Device Manager



To open Device Manager in Windows 8, 8.1 or 10:

Right click the Start Menu and then select: Device Manager

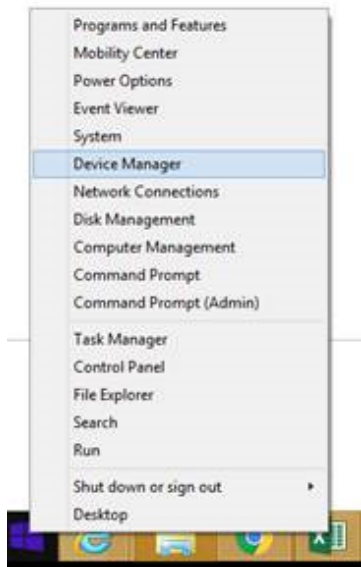

3. For macOS users, open the System Profiler to confirm that the RG2304N/2304GE-LAN has installed correctly. In the left hand column, under Hardware, select “USB” and inspect the right hand panel. If the extender system has been installed correctly, you should find it listed as a “Hub” under the USB High-Speed Bus/USB Bus.



To open System Profiler in macOS:

Open the Finder, select Applications, then open the Utilities folder and double click on the System Profiler icon.

4. If the RG2304 Series extender system is not detected correctly or fails to detect, please consult the Troubleshooting section in this guide.

## Connecting a USB Device

1. Install any software required to operate the USB device(s). Refer to the documentation for the USB device(s), as required.
2. Connect the USB device to the device port on the remote extender.
3. Check that the device is detected and installed properly in the operating system.

## Pairing the Local and Remote Extender

When bought as a complete system that consists of both a local extender and a remote extender, the RG2304N/2304S/2304GE-LAN extenders will be paired with each other out of the box, so no pairing action should be required. However, if extenders are bought individually, individual extenders have been installed, or you simply wish to change the local and remote extender pairings across a network, then the following steps must be taken:

**!** The following steps apply to both direct connect and network connect configurations for the RG2304N/2304S/2304GE-LAN.

1. Ensure the local and remote extenders are either directly connected to each other, or are connected to the same subnet on your network.
2. Press and hold the Mode button on the back of the local extender. Release the button within 10 seconds. The Link LED will start flashing. Pairing mode has been activated on the local extender.
3. Within 10 minutes of activating the pairing mode on the local extender, press and hold the Mode button on the back of the remote extender. Release this button within 10 seconds. The Link LED will start flashing. Pairing mode has been activated on the remote extender.
4. The Link LED on both units may start flashing more slowly before finally turning on. Once the Link LEDs are solid, the link is established between both extenders.



If more than 10 minutes passes before the units are paired, then the extenders will switch back to regular mode and reestablish the previous links they had, if any.



To cancel pairing mode, press and hold the 'Mode' button a second time. Release it within 10 seconds.

## Unpairing an Extender

If for any reason an extender needs to have its pairing removed, this can be done by pressing and holding the Mode button for longer than 10 seconds. Once this is completed the unit will not be paired to any other extender.

## Compatibility

The USB 2.0 RG2304 Series complies with USB 1.1 and USB 2.0 specifications governing the design of USB devices. However, there is no guarantee that all USB devices or hosts will be compatible, as there are a number of different characteristics that may impact the operation of USB devices over extended distances.

## USB Extender Mounting Options

The bottoms of the RG2304 Series enclosures feature four convenient pre-drilled holes for optional mounting. Based on your requirements, choose from two available mounting options:

1. **USB Extender Mounting Kit** (Purchased separately Order Part #10-00394 USB Mounting Kit - Black)
2. **USB Extender Direct Surface Mounting** (Using your own hardware, stencil provided on page 13)

**OPTION 1: USB Extender Mounting Kit** - each kit includes:

- 2 mounting brackets
- 4 (M3.0) locking washers
- 4 (M3.0 x 5mm) Phillips pan head screws
- Mounting bracket installation guide (*see diagram below*)

One kit is required to mount a Local Extender or Remote Extender; two kits per system.

Using a Phillips screwdriver, in the order as illustrated below, fasten and secure the provided screws, locking washers and brackets into place.

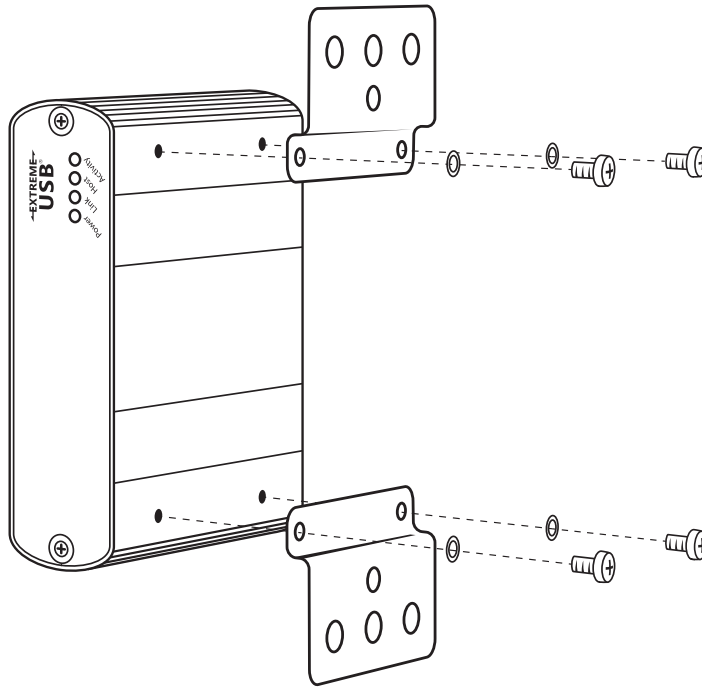

Once the bracket mounting is secured onto the extender, it is ready for mounting onto a surface. Please note you will need to provide your own screws to secure the extender using the available slots on each bracket.

## OPTION 2: USB Extender Direct Surface Mounting (using your own hardware)

The bottoms of the RG2304 Series enclosures features four pre-drilled holes for optional surface mounting.

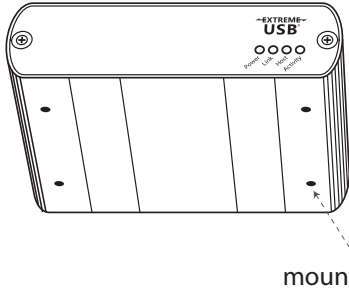

Distance between the enclosure mounting holes:  
42.0mm x 77.0mm

1. Mark the center point of each of the four holes on your mounting surface either by directly measuring or using a print out of the stencil below.
2. Hardware recommendation: M3.0 locking washers and M3.0 screws (4 of each per extender) noting screw length will depend upon thickness of mounting surface.
3. Drill through each of the four hole markings on the mounting surface using a 4.7625mm (3/16") drill bit.
4. Align the bottom enclosure holes to the newly drilled out holes on the mounting surface.
5. Place a locking washer on each of the four screws and using a screwdriver, fasten the extender into place.

**note** To ensure the stencil below prints to scale be sure to set the page scaling setting to "none".

### Direct Surface Mounting Measurement Stencil

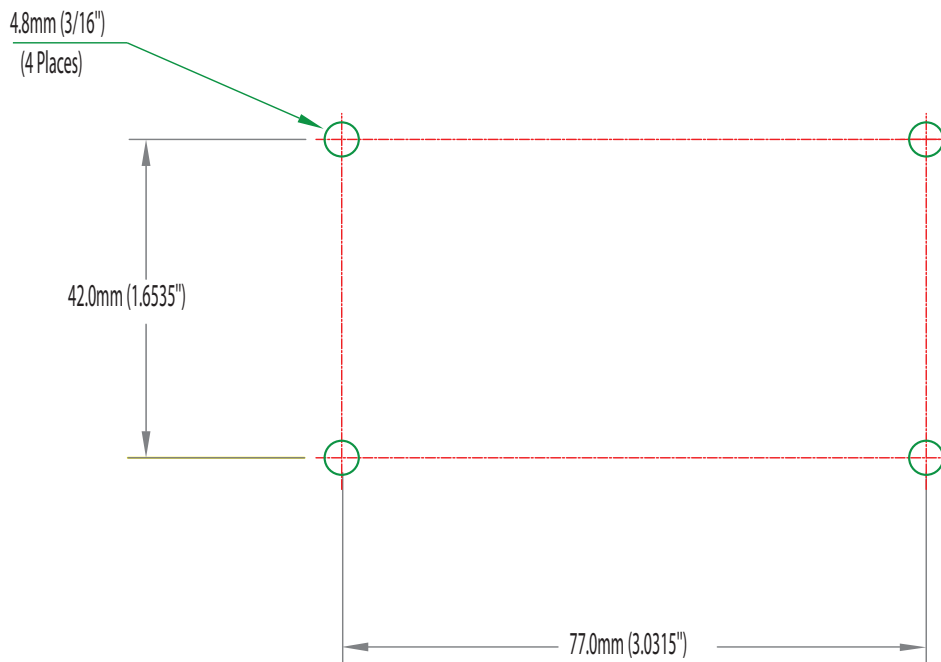

## Troubleshooting

The following table provides troubleshooting tips. The topics are arranged in the order in which they should be executed in most situations. If you are unable to resolve the problem after following these instructions, please contact Technical Support for further assistance.

<b>PROBLEM</b>	<b>CAUSE</b>	<b>SOLUTION</b>
All LEDs on the local extender are off.	<ul style="list-style-type: none"> <li>The local extender is not receiving power from the USB port.</li> </ul>	<ol style="list-style-type: none"> <li>Ensure that the host computer is connected to the local extender.</li> <li>Move the USB connector to another USB port on the host computer.</li> </ol>
All LEDs on the remote extender are off.	<ul style="list-style-type: none"> <li>The remote extender is not receiving power from the AC adapter.</li> </ul>	<ol style="list-style-type: none"> <li>Ensure that the AC power adapter is properly connected to the remote extender.</li> <li>Check that the AC adapter is connected to a live source of electrical power. Check that the remote extender's power LED is illuminated.</li> </ol>
Link LEDs on the local and the remote extenders are off.	<ul style="list-style-type: none"> <li>There is no connection between the local and remote extenders.</li> </ul>	<ol style="list-style-type: none"> <li>Ensure CAT 5e/6/7 cable is connected between the local and remote extender units; cable should be UTP or STP, with a straight through connector and no crossovers, and 8 conductor RJ45 connectors are used at both ends.</li> <li>Connect a short CAT 5e/6/7 patch cord between the local and remote extenders to determine if the original CAT 5e/6/7 cable is defective.</li> </ol>
Link LEDs are blinking.	<ul style="list-style-type: none"> <li>There is no connection between the local and remote extenders.</li> <li>Units may not be paired to each other.</li> <li>Network switches exist on different subnets.</li> <li>Network switch(es) are blocking traffic from the extenders.</li> </ul>	<ol style="list-style-type: none"> <li>Ensure both the Local and Remote Extenders are connected together directly or are connected to active network switches.</li> <li>Re-pair the units together.</li> <li>Ensure the network switches can communicate with each other and are on the same subnet.</li> <li>Ensure the network switches are not blocking traffic from the extenders either based on MAC address or due to traffic patterns.</li> <li>Consult with your network administrator.</li> </ol>

<b>PROBLEM</b>	<b>CAUSE</b>	<b>SOLUTION</b>
Link LED on the local and the remote extenders are blinking slowly.	<ul style="list-style-type: none"> <li>• The extenders are paired with each other but have not yet established a link.</li> </ul>	<ol style="list-style-type: none"> <li>1. Wait for a few minutes for the LEDs to go solid.</li> <li>2. If LEDs do not go solid, contact your network administrator to determine if any traffic is being blocked between the extenders.</li> </ol>
Link LED on the local extender is on, Host LED on the local extender is off.	<ul style="list-style-type: none"> <li>• The host computer is not powered on.</li> <li>• The local extender is not connected to the computer.</li> <li>• The host computer is not recognizing the local extender.</li> <li>• The computer does not support USB hubs.</li> <li>• The extender is malfunctioning.</li> </ul>	<ol style="list-style-type: none"> <li>1. Disconnect all USB devices from the remote extender.</li> <li>2. Disconnect the local extender from the computer.</li> <li>3. Disconnect the remote extender from the AC power adapter.</li> <li>4. Reconnect the local extender to the computer.</li> <li>5. Reconnect the remote extender to the AC power adapter.</li> <li>6. In the Universal Serial Bus controllers section of Device Manager, check that the extender system is recognized as a "Generic USB Hub".</li> </ol>
My USB device does not work properly.	<ul style="list-style-type: none"> <li>• Insufficient bandwidth is available on the network to support the device.</li> </ul>	<ol style="list-style-type: none"> <li>1. Connect the local and remote extenders directly to each other and try the USB device again.</li> </ol>
My USB device does not work at all.	<ul style="list-style-type: none"> <li>• Insufficient bandwidth is available on the network to support the device.</li> <li>• The local extender is paired to the wrong remote extender.</li> </ul>	<ol style="list-style-type: none"> <li>1. Connect the local and remote extenders directly to each other and try the USB device again.</li> <li>2. Follow the instructions on page 11 and pair the local to the remote extender that is connected to the device you wish to use.</li> </ol>



## Contacting Technical Support

If you are experiencing problems not referenced in the Troubleshooting Guide, contact Technical Support at the company where you purchased this product and provide them with the following information:

- Host computer make and model
- Type of operating system installed (e.g. Windows 8.1, Windows 10, OS X 10.11, etc.)
- Part number and serial number of both the Local Extender and Remote Extender unit
- Make and model of any USB device(s) attached to this extender system
- Description of the installation such as Host computer model, transmission media used and information about the USB device(s)
- Description of the problem

# Technical Glossary

## Category 5e/6/7 (CAT 5e/6/7) Network Cabling

Category 5e/6/7 cable is commonly also referred to as CAT 5e or CAT 6 or CAT 7. This cabling is available in either solid or stranded twisted pair copper wire variants and as UTP (Unshielded Twisted Pair) or STP (Shielded Twisted Pair). UTP cables are not surrounded by any shielding making them more susceptible to Electromagnetic Interference (EMI). STP cables include shielding around the conductors and provide better protection against EMI.

## USB 2.0 Cables

USB 2.0 cables have two distinct full-sized connectors. The Type A connector is used to connect the cable from a USB device to the Type A port on a computer or hub. The Type B connector is used to attach the USB cable to a USB device.

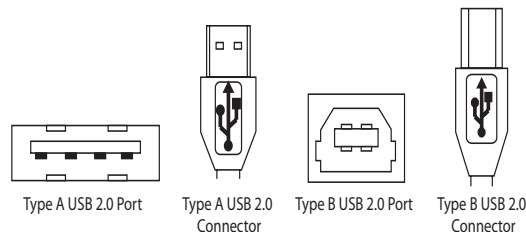

## RJ45

The Registered Jack (RJ) physical interface is what connects the network cabling (CAT 5e/6/7) to the Local Extender unit and Remote Extender unit. You may use either the T568A scheme (Table 1) or the T568B scheme (Table 2) for cable termination as the USB 2.0 RG2304N/2304GE-LAN requires all four pairs of the cable. RJ45 connectors are sometimes also referred to as 8P8C connectors. Note that any given cable must be terminated using the same T568 scheme on both ends to operate correctly.

## RJ45 Pin Positioning

Table 1 - T568A Wiring

PIN	PAIR	WIRE	CABLE COLOR
1	3	1	WHITE/GREEN
2	3	2	GREEN
3	2	1	WHITE/ORANGE
4	1	2	BLUE
5	1	1	WHITE/BLUE
6	2	2	ORANGE
7	4	1	WHITE/BROWN
8	4	2	BROWN

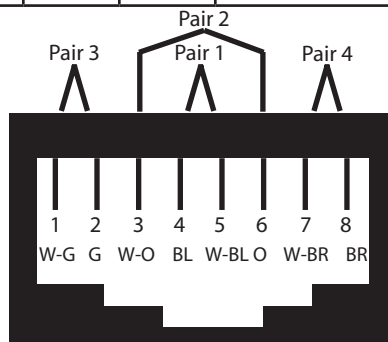
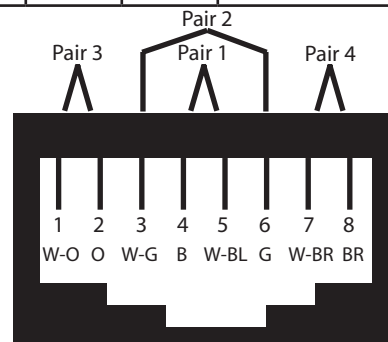

Table 2 - T568B Wiring

PIN	PAIR	WIRE	CABLE COLOR
1	2	1	WHITE/ORANGE
2	2	2	ORANGE
3	3	1	WHITE/GREEN
4	1	2	BLUE
5	1	1	WHITE/BLUE
6	3	2	GREEN
7	4	1	WHITE/BROWN
8	4	2	BROWN



## Specifications

RANGE	
Direct Connect	Up to 100m (330 ft) over solid core CAT 5e/6/7
Network Connect	Up to 100m (330 ft) between switches over solid core CAT 5e/6/7
USB DEVICE SUPPORT	
Maximum Throughput	Up to 480 Mbps*
Traffic Types	All Traffic Types
Device Types	All Device Types
Maximum Number	Up to 30 devices
NETWORKING (RG2304N, 2304S and GE-LAN models)	
Standards	1000BASE-T
Data Traffic	Layer 2
Control Traffic (RG2304S and GE-LAN only)	Layer 3, customizable as unicast or broadcast
LOCAL EXTENDER	
USB Connector	1 x USB 2.0 Type B Receptacle
Link Connector	1 x RJ45
Dimensions	100.0mm x 76.0mm x 26.0mm (3.9" x 3.0" x 1.0")
Enclosure Material	Black Anodized Aluminum
REMOTE EXTENDER	
USB Connectors	4 x USB 2.0 Type A Receptacles
Link Connector	1 x RJ45
Dimensions	100.0mm x 76.0mm x 26.0mm (3.9" x 3.0" x 1.0")
Enclosure Material	Black Anodized Aluminum
Minimum Available Current	Up to 600mA at each USB port concurrently; 1A per port when two or less being used
Power Supply	100-240V AC input, 24V 1A DC Output
ENVIRONMENTAL	
Operating Temperature Range	0°C to 50°C (32°F to 122°F)
Storage Temperature Range	-20°C to 70°C (-4°F to 158°F)
Operating Humidity	20% to 80% relative humidity, non-condensing
Storage Humidity	10% to 90% relative humidity, non-condensing
COMPLIANCE	
EMC	FCC (Class B), CE (Class B)
Environmental	RoHS2 (CE)
SUPPORT	
Warranty	2-year