



WiRanger™

Cable Free USB 2.0 Hub

User Guide



Powered by ExtremeUSB® Technology



Thank you for purchasing the WiRanger™. Please read this guide thoroughly before installation.

This document applies to Part Numbers: 00-00228G through 00-00230G.

FCC Radio Frequency Interference Statement Warning

The WiRanger has been tested and found to comply with the limits for a Class B digital device, pursuant to part 15 of the FCC Rules. These limits are designed to provide reasonable protection against harmful interference in a residential installation. The WiRanger generates, uses and can radiate radio frequency energy and, if not installed and used in accordance with the instructions, may cause harmful interference to radio communications. However, there is no guarantee that interference will not occur in a particular installation. If the WiRanger does cause harmful interference to radio or television reception, which can be determined by turning the equipment off and on, the user is encouraged to try to correct the interference by one or more of the following measures:

- Reorient or relocate the receiving antenna.
- Increase the separation between the equipment and receiver.
- Connect the equipment into an outlet on a circuit different from that to which the receiver is connected.
- Consult the dealer or an experienced radio/ TV technician for help.

FCC Radiation Exposure Statement:

This equipment complies with FCC radiation exposure limits set forth for an uncontrolled environment. This equipment should be installed and operated with a minimum distance of 20cm between the radiator and your body.

CE Statement

Icron Technologies Corporation declares that the WiRanger conforms to the specifications listed below, following the provisions of the European R&TTE directive 1999/5/EC:

Icron Technologies Corporation vakuuttaa täten että dieses produkt tyypinen laite on direktiivin 1999/5/EY oleellisten vaatimusten ja sitä koskevien näiden direktiivien muiden ehtojen mukainen.

Icron Technologies Corporation déclare que le produit est conforme aux conditions essentielles et aux dispositions relatives à la directive 1999/5/EC.

- EN 301 489-1, 301 489-17 General EMC requirements for Radio equipment.
- EN 609 50 Safety
- EN 300-328 Technical requirements for Radio equipment.

Caution: This equipment is intended to be used in all EU and EFTA countries. Outdoor use may be restricted to certain frequencies and/or may require a license for operation. Contact local Authority for procedure to follow.

Note: Combinations of power levels and antennas resulting in a radiated power level of above 100 mW equivalent isotropic radiated power (EIRP) are considered as not compliant with the above mentioned directive and are not allowed for use within the European community and countries that have adopted the European R&TTE directive 1999/5/EC.

For more details on legal combinations of power levels and antennas, contact Icron Technologies Corporation.

Belgique:

Dans le cas d'une utilisation privée, à l'extérieur d'un bâtiment, au-dessus d'un espace public, aucun enregistrement n'est nécessaire pour une distance de moins de 300m. Pour une distance supérieure à 300m un enregistrement auprès de l'IBPT est requise. Pour une utilisation publique à l'extérieur de bâtiments, une licence de l'IBPT est requise. Pour les enregistrements et licences, veuillez contacter l'IBPT.

France:

2.4 GHz Bande : les canaux 10, 11 (2457 et 2462 MHz respectivement) sont complètement libres d'utilisation en France (en utilisation intérieur). Pour ce qui est des autres canaux, ils peuvent être soumis à autorisation selon le département. L'utilisation en extérieur est soumise à autorisation préalable et très restreinte. Vous pouvez contacter l'Autorité de Régulation des Télécommunications (<http://www.art-telecom.fr>) pour de plus amples renseignements.

SAFETY NOTICES

Caution: Do not use this product near water, for example, in a wet basement or near a swimming pool.

Avoid using this product during an electrical storm. There may be a remote risk of electric shock from lightning.



IC Statement

This Class B digital apparatus complies with Canadian ICES-003 and RSS210 rules.

Cet appareil numérique de la classe B est conforme à la norme NMB-003 et CNR210 du Canada.

The use of this device in a system operating either partially or completely outdoors may require the user to obtain a license for the system according to the Canadian regulations.

To reduce potential radio interference to other users, the antenna type and its gain should be so chosen that the equivalent isotropically radiated power (e.i.r.p.) is not more than that permitted for successful communication.

This device has been designed to operate with the antennas listed below, and having a maximum gain of 2.0 dBi @ 2.4GHz. Antennas not included in this list or having a gain greater than 2.0 dBi @ 2.4GHz are strictly prohibited for use with this device. The required antenna impedance is 50 Ohms.

©2007 Icron Technologies Corporation. All rights reserved. Icron Technologies Corporation, the Icron Technologies Corporation logo, and the Icron Technologies Corporation products referred to herein are either the trademarks or the registered trademarks of Icron Technologies Corporation. All other trademarks are property of their respective owners. Icron Technologies Corporation assumes no responsibility for errors that may appear in this manual. Information contained herein is subject to change without notice.

Contents

Introduction.....	1
WiRanger Product Contents.....	1
About the WiRanger	2
Before You Begin	8
Installing the LEX unit.....	8
Installing the REX unit	8
Establishing Wireless Communication	8
Checking the Installation.....	9
Connecting a USB Device	9
Advanced Setup – Viewing and Changing the 802.11g Radio Channel ..	10
Advanced Setup – Pairing a LEX unit and a REX unit.....	13
Troubleshooting	15
Specifications.....	19
Limited Hardware Warranty	20
Hardware Remedies	20
Limitation of Liability.....	20
Obtaining Warranty Service.....	21
Contacting Technical Support.....	21

Introduction

This manual explains the installation and operation of the WiRanger – Cable Free USB 2.0 Hub. The instructions in this guide assume a general knowledge of computer installation procedures, wireless network installation requirements, and some understanding of USB devices.

 **NOTE:** Notes give additional information that could make installation easier.

WiRanger Product Contents

When you open your WiRanger for the first time you should find the following items:

- Local Extender unit or LEX unit (includes antenna)
- Remote Extender unit or REX unit (includes antenna)
- Two (2) AC power adapters
- One (1) USB cable (2m long)
- WiRanger User Guide
- WiRanger Quick Start Guide

To complete the installation, you will also require the following items that are not included with the product:

- USB 1.1 or 2.0 compatible computer
- USB device(s)

 **NOTE:** The WiRanger uses an IEEE 802.11g radio platform to wirelessly communicate between the LEX unit and the REX unit using the 2.4GHz radio frequency range. Other products, such as wireless routers and 2.4GHz cordless telephones, also broadcast in this same 2.4GHz range. Please be aware of potential interference issues with such products before you begin installation of the WiRanger.

 **NOTE:** The LEX unit and the REX unit of your new WiRanger have been “Paired” during manufacturing. This means that they will only communicate with each other, even if other WiRanger units are installed near by.

 **NOTE:** Use only the AC adapters supplied with the WiRanger. Use of substitute adapters may cause permanent damage to the system and will void the warranty.



About the WiRanger

The WiRanger is the world's first wireless USB 2.0 Hub, combining Icron's patented *ExtremeUSB*® technology and an industry standard IEEE 802.11g radio. The WiRanger Hub enables wireless connection of USB devices up to 30 meters from the host computer.

The WiRanger installs as a Generic USB Hub and requires no additional software drivers to be installed. It is composed of two individual units, the LEX unit, which connects to the host computer, and the REX unit, which connects to the remote USB device(s).

Features:

- Supports USB 1.1 (low-speed, full-speed) and USB 2.0 (high-speed) devices.
- True plug-and-play, no new drivers required. Ready to operate straight out of the box
- Supports major operating systems including Windows XP, 2000 or Vista, Mac OS, and Linux
- Four port USB 2.0 Hub on remote unit. Additional hub connections supported for more devices
- Recommended for use with keyboards, mice, and mass storage USB 2.0 devices which require moderate levels of bandwidth.
- User selectable radio channel to improve co-existence with deployed 802.11 networks
- System powered at both local (PC host unit) and remote (USB hub) units

The LEX unit

The LEX unit connects to the host computer using a conventional USB cable. It also connects to a power outlet through an AC power adapter.

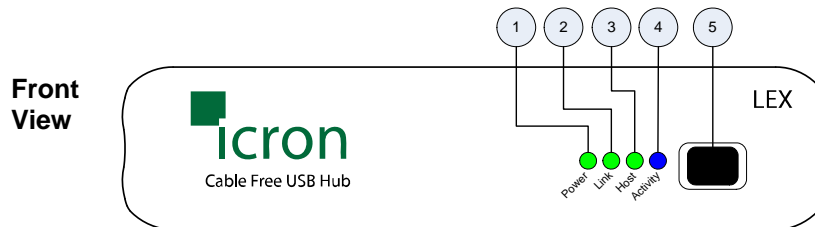

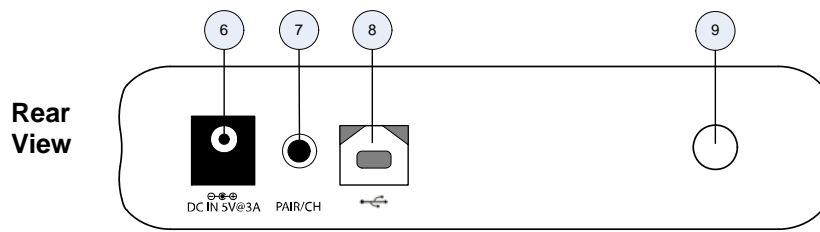

Rear View

- | | |
|-------------------------------|---------------------------------------|
| 1 Power LED | 6 Power connector (5V @ 3A) |
| 2 Link LED | 7 Pair/Channel Change Button** |
| 3 Host LED | 8 Host port (USB Type-B) |
| 4 Activity LED | 9 Antenna connector |
| 5 Infra Red (IR) Port* | |

* IR port used to pair the LEX unit and the REX unit only

** Pair/CH button is for advanced users only. See Pages 10 and 13 for advanced instructions.

The REX unit

The REX unit allows you to connect up to four USB devices directly; additional devices may be connected by attaching a conventional USB hub to one of the device ports. The REX unit also connects to a power outlet through an AC power adapter.

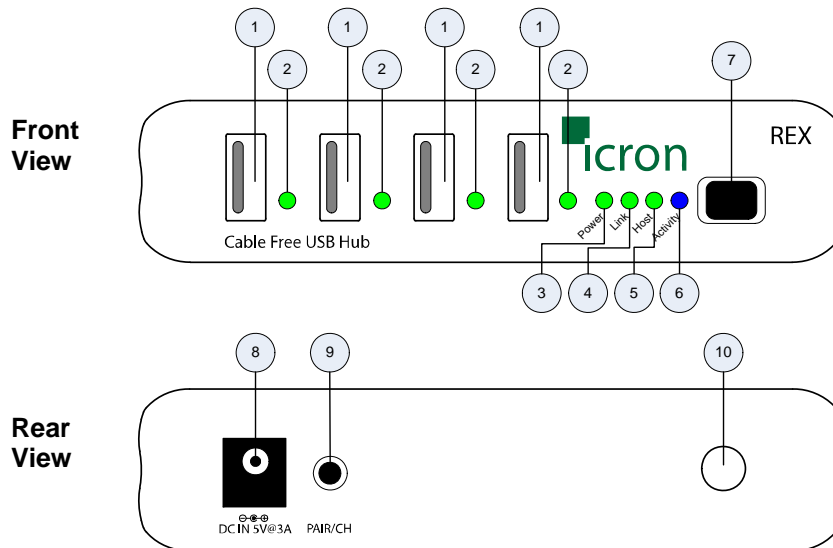

Front View

Rear View



- | | |
|------------------------------------|---------------------------------------|
| <u>1</u> Device ports (USB Type-A) | <u>6</u> Activity LED |
| <u>2</u> Device LED's | <u>7</u> Infra Red (IR) Port* |
| <u>3</u> Power LED | <u>8</u> Power connector (5V @ 3A) |
| <u>4</u> Link LED | <u>9</u> Pair/Channel Change Button** |
| <u>5</u> Host LED | <u>10</u> Antenna connector |

* IR port used to pair the LEX unit and the REX unit only

** Pair/CH button is for advanced users only. See Pages 10 and 13 for advanced instructions.

WiRanger LED Descriptions

The WiRanger uses LED's to indicate status to the user. LED operation is the same for the LEX unit and the REX unit.

LED Name	Description
Power LED	Indicates 5V power is connected to the unit.
Link LED	Indicates communications have been established between the LEX unit and the REX unit. Independent of USB communication.
Host LED	Indicates successful communications between the host PC and the USB 2.0 hub in the REX unit.
Activity LED	Indicates active USB data transmission and/or reception over the wireless link. Additionally, the Activity LED will flash after power is connected to indicate that the radios are powering up
Device LED's (REX unit only)	<p>GREEN: Indicates that the attached USB device is correctly detected by the host PC.</p> <p>ORANGE: Indicates that the attached USB device has drawn too much current and hence the hub has shut this Device port off to protect the WiRanger. Disconnect and reconnect the REX unit's power to clear this fault condition.</p>



Wireless Operation

The LEX unit and REX unit wirelessly communicate over the IEEE 802.11g radio protocol at a distance up to 30 meters. The actual communications distance will vary greatly depending on the amount and type of physical obstacles and radio interference in your area. In general, the WiRanger should have similar range to that of a normal 802.11g router or access point.



The LEX unit and REX unit of this WiRanger are “Paired” at the factory so that they will only communicate with each other, even if other WiRanger’s are installed near by.

NOTE: Under normal operating conditions, you should never need to “Pair” the units. However, if absolutely required, the units can be “Paired” using the procedure listed on Page 13, Advanced Setup – Pairing a LEX unit and a REX unit.

The IEEE 802.11g standard allows for different wireless devices to operate on different Radio Channels. This means that your 802.11g wireless router or access point can co-exist with the WiRanger, if they are configured to operate on different channels.

Your WiRanger will be pre-configured to operate on 802.11g Radio Channel 11. Ideally, your other 802.11g products should be configured to work on a channel that is at least 5 channels apart from the one used by the WiRanger.

For example, if the WiRanger is on channel 11 and you also have a 802.11b/g router. Then configure the router to operate on channel 6, or lower.

NOTE: If required, you can view or change the current WiRanger 802.11g Radio Channel. See Advanced Setup – Viewing and Changing the 802.11g Radio Channel on Page 10 for instructions.

 **NOTE:** The WiRanger does not broadcast an SSID and will not be visible to a wireless network scan.

USB Cables

USB cables have two distinct connectors. The Type A connector is used to connect the cable from a USB device to the Type A port on a computer or hub. The Type B connector is used to attach the USB cable to a USB device.

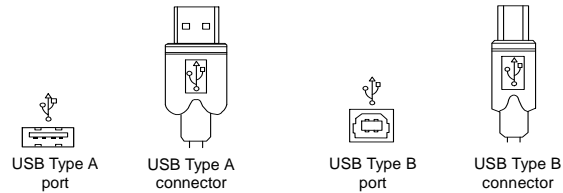

Compatibility

The WiRanger complies with USB 2.0 specifications governing the design of high-speed USB devices. However, because of the data rate limitations inherent in the IEEE 802.11g radio platform, Icron Technologies Corporation does not guarantee that all USB devices are compatible with the WiRanger.

In particular, webcams that use the BULK transfer protocol are not supported. For more information on potential incompatibilities, please see the FAQ page of the Icron Technologies Corporation website:

<http://www.icron.com/products/usb/faq.php>

Or contact Technical Support for further assistance (see page 21).



Before You Begin

Before you can install the WiRanger, you need to prepare your site.

1. Set up the host computer in an appropriate location.
2. Determine where you want to locate the USB device(s).
3. Determine suitable locations for the LEX unit and the REX unit such that they will be able to maintain wireless communication. Physical obstacles and other radio wave emitting devices can cause interference that will reduce the maximum distance and data rate between the LEX unit and the REX unit.
4. If other 802.11g based products will be in operation in the same area, determine the optimal Radio Channel selection for all wireless products. See the Wireless Operation section on Page 6 for more information on channel selection.

Installing the LEX unit

1. Place the LEX unit near the host computer.
2. Plug the Type-B connector on the USB cable (included) into the Host port on the LEX unit.
3. Plug the Type-A connector on the USB cable into the USB port on the computer.
4. Plug the power adapter into a suitable AC outlet.
5. Connect the power adapter to the LEX unit.

Installing the REX unit

1. Place the REX unit near the USB device(s), no more than 30m from the LEX unit.
2. Plug the power adapter into a suitable AC outlet.
3. Connect the power adapter to the REX unit.

Establishing Wireless Communication

The WiRanger will automatically establish a wireless connection between the LEX unit and the REX unit once power is applied to both units and they are located within their operating range. The Link LED on both units will turn *on* once the wireless connection has been made.

-  **NOTE:** It may take up to 30 seconds for the WiRanger to establish wireless communication. The Activity LED will flash during this time to indicate that the radios are powering up.

Checking the Installation

Once the Activity LED's on the LEX unit and REX unit stop flashing after power up:

1. Check that the Power LED's on the LEX unit and REX unit are both *on*.
2. Check that the Link LED's on the LEX unit and REX unit are both *on*.
3. Check that the Host LED's on the LEX unit and REX unit are both *on*.
4. For Windows users (2000, XP, or Vista) open Device Manager to confirm that the WiRanger has installed correctly. Expand the entry for Universal Serial Bus controllers by clicking the + sign. If the WiRanger has been installed correctly you should find it listed as a Generic USB Hub.
 - ✎ **NOTE:** To open Device Manager in Windows 2000 or XP: Right-click My Computer then select Properties, select the Hardware tab and click the Device Manager button
 - ✎ **NOTE:** To open Device Manager in Windows Vista: Open the Start menu, right-click on Computer, select Manage and finally click on "Device Manager" in the left-hand tree
5. For Mac OS X users open the System Profiler to confirm that the WiRanger has installed correctly. In the left hand column under Hardware, select "USB" and inspect the right hand panel. If the WiRanger has been installed correctly you should find it listed as a Hub under the USB High-Speed Bus.
 - ✎ **NOTE:** To open System Profiler in OS X: Open the Finder, select Applications, then open the Utilities folder and double click on the System Profiler icon.

Connecting a USB Device

1. Install any software required to operate the USB device(s). Refer to the documentation for the device(s), as required.
2. Connect the USB device(s) to the Device port(s) on the REX unit.
3. Check that the Device LED on the REX unit is on.
4. Confirm on the host PC that the each connected device operates as expected.

Advanced Setup – Viewing and Changing the 802.11g Radio Channel

The following instructions are for advanced users only.

These instructions should only be executed if specifically required and if you are comfortable with the operations. Under normal operating conditions, you should not need to view or change the 802.11g Radio Channel.

Viewing the Current 802.11g Radio Channel

- 🔍 **NOTE:** Radio Channel viewing can be done on either the LEX unit or the REX unit. The procedure is the same.
 - 🔍 **NOTE:** Viewing the current 802.11g Radio Channel will not disrupt normal USB communication between the LEX unit and the REX unit.
1. Power on either the LEX unit or the REX unit and wait for approximately 20 seconds before proceeding to step 2. If the unit is already on, proceed to step 2.
 2. On the selected LEX unit or REX unit, press and hold (do not release) the Pair/CH button for a minimum of 10 seconds. The button can be released when the Host, Link and Activity LED's start to blink rapidly.
 3. Upon release of the Pair/CH button the current 802.11g Radio Channel will be displayed as a pattern on the Host, Link, and Activity LED's. Please see the figure below for the description of the LED Radio Channel patterns.

Radio Channel	LED Pattern		
	Link	Host	Activity
1	●	○	○
6	●	●	○
11	●	●	●

4. **DO NOT** press the Pair/CH button again. After 60 seconds the selected LEX unit or REX unit LED's will return to their normal operation.
- 🔍 **NOTE:** If the button is pressed again and a Channel Change is not desired, **DO NOT** press the button again. After 60 seconds from last button press the selected LEX unit or REX unit LED's will return to their normal operation and no change in the unit's channel selection will be made.

NOTE: If power is removed from the unit while the Channel LED Pattern is still active, no change in the units channel selection will be made.

Changing the 802.11g Radio Channel

The WiRanger can operate on one of three 802.11g radio channels. Each radio channel broadcasts data in a different frequency band within the 2.4GHz range. The WiRanger can be configured to operate on channels: 1, 6, and 11.

By selecting a different Radio Channel, you can try to find a channel with minimal radio interference. This can improve signal quality and data rates.

NOTE: When changing the Radio Channel for a “Paired” system, the channel change **MUST BE** completed on **BOTH** the LEX unit and the REX unit. The order is non-specific.

NOTE: **STOP** all devices connected to the REX unit prior to changing the channel on either unit. Changing the Radio Channel will disrupt USB traffic.

1. Power on either the LEX unit or the REX unit and wait for approximately 20 seconds before proceeding to step 2. If the unit is already on, proceed to step 2.
2. On the selected LEX unit or REX unit, press and hold (do not release) the Pair/CH button for a minimum of 10 seconds. The button can be released when the Host, Link and Activity LED’s start to blink rapidly.
3. Upon release of the Pair/CH button the current 802.11g Radio Channel will be displayed by as a pattern on the Host, Link, and Activity LED’s. Please see the figure below for the description of the LED Radio Channel patterns.

Radio Channel	LED Pattern		
	Link	Host	Activity
1	●	○	○
6	●	●	○
11	●	●	●

4. To change the channel press and release the Pair/CH button until the desired channel pattern as seen in the above figure is visible on the LED’s. Upon reaching channel 11 the pattern will return to channel 1.

- ✍ **NOTE:** If the Pair/CH button is not pressed for 60 seconds the LED's will return to their normal operation and no changes will be made to the current channel selection.
- ✍ **NOTE:** If wireless communication is present it will continue until a channel change is confirmed.
- 5. Once the desired 802.11g Radio Channel is displayed, press and hold the Pair/CH button for 10 seconds. The button can be released when the Host, Link and Activity LED's start to blink rapidly.
- ✍ **NOTE:** If the LED's do not start blinking rapidly within 20 seconds release the button and confirm that the LED pattern still shows your desired channel pattern. If it does, repeat step 5. If it does not, return to step 4.
- 6. Upon release of the Pair/CH button the LED's will continue to blink for approximately 20 seconds while the Channel Change is stored and the 802.11g radio reboots. Once the blinking stops the Channel Change is complete.
- ✍ **NOTE:** **DO NOT** remove power while LED's are blinking.
- ✍ **NOTE:** If the channel selection on the LEX unit and the REX unit are no longer the same the USB traffic will now stop. If the channel selection on the LEX and REX are made the same the USB traffic will begin.
- 7. If only one side of the system has been changed repeat steps 1 to 6 for the other side of the system. If channel selection is complete on both sides of the system go to step 8.
- 8. Connect a USB cable between the WiRanger and the host PC, and confirm its operation by checking if it is listed in Device Manager (for Windows installations), or System Profiler (for Mac OS X installations) under Universal Serial Bus controllers as a "Generic USB Hub".

Advanced Setup – Pairing a LEX unit and a REX unit

The following instructions are for advanced users only.

These instructions should only be executed if specifically required and if you are comfortable with the operations. Under normal operating conditions, you should never need to pair a LEX unit and a REX unit.

Paired units are defined as a LEX unit and a REX unit that are aware of each other's unique address and communicate exclusively.

Pairing is accomplished by infrared (IR) communication through the IR windows on the LEX unit and the REX unit; pairing information is not sent over the 802.11g radios. The IR communication distance is limited to an approximate distance of 20 cm.

- ✔ **NOTE:** The WiRanger's LEX unit and REX unit are shipped paired from the factory.
- ✔ **NOTE:** If the Pair/CH button is pressed whether accidentally or purposefully and the LEX unit and the REX unit are not able to communicate via the IR interface no effect in operation will be detected and pairing will not occur.
- 1. Place the LEX unit and the REX unit 5 cm apart from each other with their IR windows pointed directly at each other. The IR windows must have a clear and unobstructed view of each other.
- 2. Power on both the LEX unit and the REX unit and wait for approximately 20 seconds before proceeding to step 3. If the units are already on, proceed to step 3.
- 3. Press the Pair/CH button on either unit for approximately 1 second. Upon release of the button the Host, Link and Activity LED's on both the LEX unit and the REX unit should begin to blink rapidly.
- ✔ **NOTE:** **DO NOT** remove power while LED's are blinking.
- ✔ **NOTE:** If step 3 is attempted too early after power up, the pairing procedure will not occur. Wait a few seconds longer and retry step 3.
- ✔ **NOTE:** If the rapid blinking of the LED's does not occur, confirm that the IR windows on the LEX unit and the REX unit are unobstructed, pointed at each other, and are 5 cm apart. Retry pressing the PAIR button. If the LED's still do not blink upon release of the button unplug both units for at least 10 seconds and return to step 1.



4. Wait for the LED's on the LEX unit and the REX unit to stop blinking and for the Link LED to turn on.
- 📌 **NOTE:** If the Link LED does not turn on within 30 seconds return to step 1.
5. The LEX unit and the REX unit are now Paired and are free to be unplugged and moved to their desired locations.
 6. Once the units are installed in their specific locations, connect a USB cable between the WiRanger and the host PC to confirm the WiRanger's operation. If the system has been installed and paired correctly it should be listed in Device Manager (for Windows installations), or System Profiler (for Mac OS X installations) under Universal Serial Bus controllers as a "Generic USB Hub".

Troubleshooting

The following table provides troubleshooting help. The topics are arranged in the order in which they should be executed in most situations. If you are unable to resolve the problem after following these instructions, please contact technical support for further assistance (see page 21).

Symptoms/Cause	Remedy
All LEDs on LEX unit and REX unit are off. Cause: The WiRanger is not receiving power from the adapter	<ol style="list-style-type: none"><li data-bbox="675 478 1196 531">1. Ensure that the power adapters are connected to both the LEX unit and the REX unit<li data-bbox="675 537 1196 590">2. Check that the adapters are connected to a live source of electrical power

Symptoms/Cause	Remedy
<p>Link LEDs on LEX unit and REX unit are off.</p> <p>Cause:</p> <p>There is no wireless connection between the LEX unit and the REX unit because:</p> <ul style="list-style-type: none"> a) The units are too far apart or there are too many obstructions between them. b) There is too much Radio Interference. c) The WiRanger is not configured correctly. d) The WiRanger is malfunctioning. 	<p>Move the LEX unit and REX unit together so that they are about 1 meter apart (3') and power both units. Confirm that they can establish a radio link.</p> <p>If the WiRanger <i>can</i> establish wireless communications at short range:</p> <ol style="list-style-type: none"> 1. The original LEX unit and REX unit placement is too far apart. Move the units to physically closer positions that have fewer obstacles in the way (walls, ceilings, etc). 2. And/or, there is excessive Radio Interference on the 802.11g Radio Channel. 3. Using standard Wireless Networking software, confirm if there are any other 802.11g radio networks operating on or near the same channel as the WiRanger. (Note you can determine the current WiRanger Radio Channel using the procedure on Page 10.) 4. Configure all conflicting 802.11g products so that they use evenly separated Radio Channels. Optimal separation is five channels, so channels 1, 6, and 11 will provide the least interference between themselves. <p>If the WiRanger <i>cannot</i> establish wireless communications at short range:</p> <ol style="list-style-type: none"> 1. Confirm that the Radio Antennas are properly secured to the antenna connectors of the WiRanger. 2. Confirm the Radio Channels of the LEX unit and the REX unit as described on Page 10. 3. If the LEX unit and the REX unit are not configured with the same Radio Channels, then set both units to the same channel as described on Page 11. 4. If both units are already configured to the same Radio Channel, then attempt the Pairing Procedure described on Page 13. 5. If the above procedures cannot establish wireless communications, then contact Technical Support for further assistance (see page 21).

Symptoms/Cause	Remedy
<p>Link LED on LEX unit is on; Host LED on LEX unit is off.</p> <p>Cause:</p> <p>a) The computer is not functioning. b) The LEX unit is not connected to the computer. c) There is too much Radio Interference for USB communication to succeed. d) The WiRanger is malfunctioning.</p>	<ol style="list-style-type: none"> 1. Disconnect all USB devices from the REX unit. 2. Disconnect the LEX unit from the computer. 3. Disconnect and then reconnect the power adapters to the WiRanger. 4. Reconnect the LEX unit to the computer. 5. In the Universal Serial Bus controllers section of Device Manager, check that the WiRanger is recognised as a "Generic USB Hub". 6. If the problem persists, move the LEX unit and REX unit together so that they are about 1 meter apart (3') and power both units and connect the LEX unit to the host PC. 7. Confirm that the WiRanger can establish a radio link and that the Host LED's turn on. 8. If the WiRanger is still not recognised, contact Technical Support for assistance (see page 21).
<p>A device is connected to REX unit and the corresponding Device LED is off</p> <p>Cause:</p> <p>a) The USB device is malfunctioning. b) The computer does not recognise the USB device. c) The application software for the device is not operating. d) The WiRanger is malfunctioning.</p>	<ol style="list-style-type: none"> 1. Disconnect the WiRanger from the computer. 2. Connect the USB device directly to the USB port on the computer. 3. If the device does not operate properly, consult the user documentation for the device. 4. If the device operates properly when directly connected to the computer, connect another device (of a different type) to the WiRanger. Connect the WiRanger to the computer. 5. If the second device does not operate, the WiRanger may be malfunctioning. Contact Technical Support for assistance (see page 21). 6. If the second device does operate properly, the first device may not be compatible with the WiRanger. Contact Technical Support for assistance (see page 21).

Symptoms/Cause	Remedy
<p>All LEDs on both the LEX unit and REX unit are on but the device does not operate correctly</p> <p>Cause:</p> <ul style="list-style-type: none"> a) The USB device is malfunctioning. b) The computer does not recognise the USB device. c) The application software for the device is not operating. d) The WiRanger is malfunctioning. 	<ol style="list-style-type: none"> 1. Disconnect the WiRanger from the computer. 2. Connect the USB device directly to the USB port on the computer. 3. If the device does not operate properly, consult the user documentation for the device. 4. If the device operates properly when directly connected to the computer, connect another device (of a different type) to the WiRanger. Connect the WiRanger to the computer. 5. If the second device does not operate, the WiRanger may be malfunctioning. Contact Technical Support for assistance (see page 21). 6. If the second device does operate properly, the first device may not be compatible with the WiRanger. Contact Technical Support for assistance (see page 21).

Specifications

Radio Max Data Rate*	54Mbps (802.11g)
USB device support	High-speed devices (480 Mb/s) Full speed devices (12 Mb/s) Low speed devices (1.5 Mb/s)
USB host support	USB 1.1: UHCI & OHCI USB 2.0: EHCI
Upstream USB hub support	Yes
Downstream USB hub support	Yes
Maximum Devices Connected	14 including USB hubs
Security	Standard 64 bit WEP security enabled by Radio
AC adapter(s)  NOTE: Use only the AC adapters provided with the WiRanger.	Input: 110/240 V AC, 50 – 60 Hz Output: 5 V DC, 3 A
Power available to USB device at REX unit	4 x 500 mA
USB cable	2 meters (6.6 ft)
LEX unit connector (upstream)	1 x USB Type B
REX unit connector (downstream)	4 x USB Type A
LEX unit dimensions	110mm x 69mm x 28mm (4.33" x 2.72" x 1.10")
LEX unit weight	0.18 kg (0.40 lbs.)
REX unit dimensions	110mm x 69mm x 28mm (4.33" x 2.72" x 1.10")
REX unit weight	0.20kg (0.45 lbs.)
System shipping weight	1.04 kg (2.30 lbs.)
Temperature range	4°C to 40°C
Regulatory testing	FCC Class B, IC, CE Class B

**actual performance will vary depending on operating environment*



Limited Hardware Warranty

Icron Technologies Corporation warrants that any hardware products accompanying this documentation shall be free from significant defects in material and workmanship for a period of one year from the date of purchase. Icron Technologies Corporation's hardware warranty extends to Licensee, its customers and end users.

Hardware Remedies

Icron Technologies Corporation's entire liability and the Licensee's exclusive remedy for any breach of warranty, shall be, at Icron Technologies Corporation's option, either (a) return of the price paid or (b) repair or replacement of hardware, which will be warranted for the remainder of the original warranty period or 30 days, whichever is longer. These remedies are void if failure of the hardware has resulted from accident, abuse, or misapplication.

Limitation of Liability

The hardware warranty set forth in this agreement replaces all other warranties. Icron Technologies Corporation expressly disclaims all other merchantability and fitness for a particular purpose and non-infringement of third-party rights with respect to the hardware. Icron Technologies Corporation dealer, agent, or employee is authorized to make any modification, extension, or addition to this warranty. Under no circumstances will Icron Technologies Corporation, its suppliers or licensors be liable for any costs of procurement or substitute products or services, lost profits, loss of information or data, or any other special, indirect, consequential, or incidental damages arising in any way out of the sale of, use of, or inability to use Icron Technologies Corporation product or service, even if Icron Technologies Corporation, its suppliers or licensors have been advised of the possibility of such damages. In no case shall Icron Technologies Corporation, its suppliers and licensors' liability exceed the actual money paid for the products at issue. Because some jurisdictions do not allow the limitation of implied warranties of liability for incidental, consequential, special, or indirect damages, the above limitation may not always apply. The above limitations will not apply in case of personal injury where and to the extent that applicable law requires such liability.

Obtaining Warranty Service

To obtain warranty service, you must contact Icron Technologies Corporation within the warranty period for a Return Material Authorization (RMA) number. Be sure you have the serial numbers of the LEX unit and REX unit units before calling. Package the product appropriately for safe shipment and mark the RMA number on the outside of the package. The package must be sent prepaid to Icron Technologies Corporation. We recommend that you insure it or send it by a method that provides for tracking of the package. The repaired or replaced item will be shipped to you, at Icron Technologies Corporation's expense, not later than thirty days after Icron Technologies Corporation receives the defective product.

Address the returned product to:

RMA Coordinator
Icron Technologies Corporation
4664 Lougheed Highway, Suite 221
Burnaby, BC, V5C 5T5
Canada
Tel: +1 604-638-3920

Contacting Technical Support

If you require technical assistance, send an e-mail message to:

techsupport@icron.com

To help us serve you better, please include the following information with your technical support request:

- Description of the problem
- Host computer make and model
- Type of operating system installed (e.g. Windows XP, Mac OS X, etc.)
- Part number and serial number of the LEX unit and the REX unit
- Make and model of any USB device attached to the WiRanger
- Description of the installation

Notes



Icron Technologies Corporation

4664 Lougheed Highway, Suite 221
Burnaby, BC, V5C 5T5
Canada

Tel: +1 604-638-3920

Fax: +1 604-638-3930

www.icron.com

90-00335-A07