

USB Rover 200



Rover 200 - Product Highlights

The USB Rover 200 is a USB 1.1 device that extends the range of USB up to 40 meters over fiber optic cable.

Using 2 strands of multimode fiber, the Rover 200 provides exceptional reliability and immunity to interference.

- Provides complete electrical isolation between computer and device.
- Compatible with PC, Mac, Sun.
- Contains internal USB hub.
- Provides support for any full-speed (12Mb/s) or low-speed (1.5 Mb/s) USB device.
- System includes local and remote units, integrated cable, international power adapter and user guide.

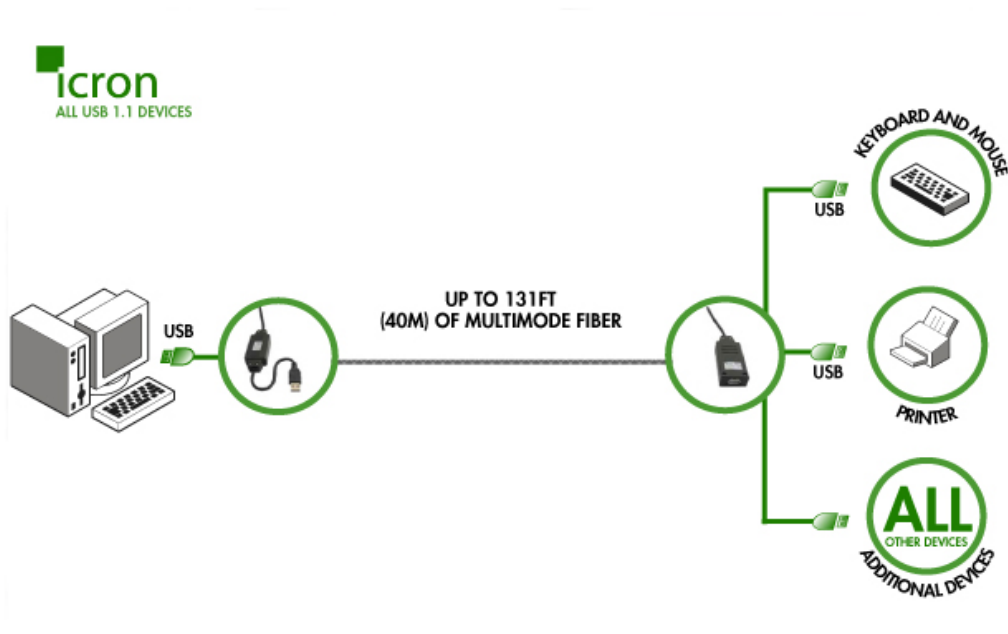



Ordering Information

USB Rover 200 products are supplied complete with a Local Extender (LEX) unit, a Remote Extender (REX) unit, an integrated fiber-optic cable, international power adapter and user guide.

USB Rover 200 Description	Part Number		
	North America	Europe	United Kingdom
USB Rover 200, 10 meter cable	00-00166G	00-00167G	00-00168G
USB Rover 200, 20 meter cable	00-00169G	00-00170G	00-00171G
USB Rover 200, 30 meter cable	00-00172G	00-00173G	00-00174G
USB Rover 200, 40 meter cable	00-00175G	00-00176G	00-00177G

Specifications

Maximum range	40 meters (132 ft)
Cable characteristics	Riser jacket of retardant PVC with 2 strands of multimode fiber of dimension 62.5/125 μ m. Tensile strength: 1200 N Minimum bend radius: 6.8 cm Outside diameter: 4.5 mm
USB device support	1 x full-speed (12 Mb/s) or low-speed (1.5 Mb/s) device.
USB hub support	Conventional USB hubs may be connected in series with the USB Rover 200. The maximum number of such hubs is: 10 meter cables: 4 hubs 20 meter cables: 3 hubs 30 meter cables: 2 hubs 40 meter cables: 1 hub
Maximum power available to USB at REX unit	500 mA
Power adapter capacity	5V DC @ 1A (connected at REX)
LEX unit connector (upstream)	1 x USB Type A
REX unit connector (downstream)	1 x USB Type A
LEX unit dimensions	87 mm x 30 mm x 16 mm (3.45" x 1.2" x 0.65")
REX unit dimensions	80 mm x 30 mm x 16 mm (3.15" x 1.2" x 0.65")
Total system shipping weight	10 m: 0.8 kg (1.8 lb) 20 m: 1.0 kg (2.2 lb) 30 m: 1.4 kg (3.0 lb) 40 m: 1.6 kg (3.4 lb)
Temperature range	0°C to 50°C
Regulatory testing	FCC, CE Class B

Specifications subject to change without notification

